

# SOUND WAVES

Wave motion is a mode of transmission of energy through a medium in the form of a disturbance. It is due to the repeated periodic motion of the particles of the medium about an equilibrium position transferring the energy from one particle to another.

The waves are of three types - mechanical, electromagnetic and matter waves. Mechanical waves can be produced only in media which possess elasticity and inertia. Water waves, sound waves and seismic waves are common examples of this type. Electromagnetic waves do not require any material medium for propagation. Radio waves, microwaves, infrared rays, visible light, the ultraviolet rays, X rays and  $\gamma$  rays are electromagnetic waves. The waves associated with particles like electrons, protons and fundamental particles in motion are matter waves.

## Characteristics of wave motion

- (i) Wave motion is a form of disturbance travelling in the medium due to the periodic motion of the particles about their mean position
- (ii) It is necessary that the medium should possess elasticity and inertia.
- (iii) All the particles of the medium do not receive the disturbance at the same instant (i.e) each particle begins to vibrate a little later than its predecessor.
- (iv) The wave velocity is different from the particle velocity. The velocity of a wave is constant for a given medium, whereas the velocity of the particles goes on changing and it becomes maximum in their mean position and zero in their extreme positions.
- (v) During the propagation of wave motion, there is transfer of energy from one particle to another without any actual transfer of the particles of the medium.
- (vi) The waves undergo reflection, refraction, diffraction and interference

## Mechanical wave motion

The two types of mechanical wave motion are (i) transverse wave motion and (ii) longitudinal wave motion

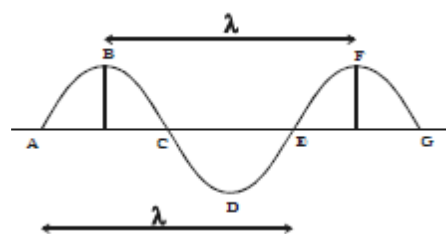

### (i) Transverse wave motion

Transverse wave motion is that wave motion in which particles of the medium execute SHM about their mean positions in a direction perpendicular to the direction of propagation of the wave. Such waves are called transverse waves. Examples of transverse waves are waves produced by plucked strings of veena, sitar or

violin and electromagnetic

waves. Transverse waves travel in the form of crests and troughs. The maximum displacement of the particle in the positive direction i.e. above its mean position is called

crest and maximum displacement of the particle in the negative direction i.e below its mean position is called trough.

Thus if ABCDEFG is a transverse wave, the points B and F are crests while D is trough For the propagation of transverse waves, the medium must possess force of cohesion and volume elasticity.

Since gases and liquids do not have rigidity (cohesion), transverse waves cannot be produced in gases and liquids. *Transverse waves can be produced in solids and surfaces of liquids only*

### (ii) Longitudinal wave motion

'Longitudinal wave motion is that wave motion in which each particle of the medium executes simple harmonic motion about its mean position along the direction of propagation of the wave.'

Sound waves in fluids (liquids and gases) are examples of longitudinal wave. When a longitudinal wave travels through a medium, it produces compressions and rarefactions. In the case of a spiral spring, whose one end is tied to a hook of a wall and the other end is moved forward and backward, the coils of the spring vibrate about their original position along the length of the spring and longitudinal waves propagate through the spring

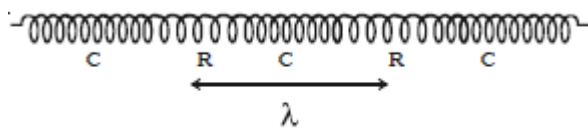

*Compression and rarefaction in spring*

The regions where the coils are closer are said to be in the state of compression, while the regions where the coils are farther are said to be in the state of rarefaction.

When sound waves pass through that region of air, the air molecules in certain region are pushed very close to each other during their oscillations. Hence, both density and pressure of air increase in such regions. In such region condensation is said to be formed. In the regions between two consecutive condensations, the air molecules are found to be quite separated. In such region density and pressure of air decrease and rarefaction is said to be formed.

Compressive strain is produced during the propagation of waves, which is possible in solid, liquids and gases medium.

### Important terms used in wave motion

#### (i) Wavelength ( $\lambda$ )

*The distance travelled by a wave during which a particle of the medium completes one vibration is called wavelength.* It is also defined as the distance between any two nearest particles on the wave having same phase.

Wavelength may also be defined as the distance between two successive crests or troughs in transverse waves, or the distance between two successive compressions or rarefactions in longitudinal waves.

**(ii) Time period (T)**

The time period of a wave is the time taken by the wave to travel a distance equal to its wavelength.

**(iii) Frequency (n)**

This is defined as the number of waves produced in one second. If T represents the time required by a particle to complete one vibration, then it makes  $1/T$  waves in one second.

Therefore frequency is the reciprocal of the time period

(i.e)  $F = 1/T$

**Relationship between velocity, frequency and wavelength of a wave**

The distance travelled by a wave in a medium in one second is called the velocity of propagation of the wave in that medium. If v represents the velocity of propagation of the wave, it is given by

$$\text{Velocity} = \frac{\text{Distance}}{\text{time}}$$

$$v = \frac{\lambda}{T} = \lambda f$$

The velocity of a wave (v) is given by the product of the frequency and wavelength.

**Velocity of wave in different media**

The velocity of mechanical wave depends on elasticity and inertia of the medium

**Velocity of a transverse wave along a stretched string**

If m is the mass per unit length of the string

If T is the tension in string. Then velocity of wave

$$v = \sqrt{\frac{T}{m}}$$

The speed of a wave along a stretched ideal string depends only on the tension and the linear mass density of the string and does not depend on the frequency of the wave

**Velocity of longitudinal waves in an elastic medium**

Velocity of longitudinal waves in an elastic medium is

$$v = \sqrt{\frac{E}{\rho}}$$

where E is the modulus of elasticity,  $\rho$  is the density of the medium.

(i) In the case of a solid rod

$$v = \sqrt{\frac{Y}{\rho}}$$

where  $Y$  is the Young's modulus of the material of the rod and  $\rho$  is the density of the rod.

(ii) In liquids,

$$v = \sqrt{\frac{B}{\rho}}$$

where  $B$  is the Bulk modulus and  $\rho$  is the density of the liquid

### Newton's formula for the velocity of sound waves in air

Newton assumed that sound waves travel through air under isothermal conditions (i.e) temperature of the medium remains constant.

The change in pressure and volume obeys Boyle's law.

$PV = \text{constant}$

Differentiating we get

$P dV + V dP = \text{constant}$

$$\therefore P - V \frac{dP}{dV} = \frac{dP}{dV/V} = \text{Bulk Modulus } B$$

Thus, isothermal bulk modulus  $B = \text{Pressure } P$

$$\therefore v = \sqrt{\frac{B}{\rho}} = \sqrt{\frac{P}{\rho}}$$

Since solids and liquids are much less compressible than gases, speed of sound in gasses is higher.

### Laplace's correction

The experimental value for the velocity of sound in air is  $332 \text{ m s}^{-1}$ . But the theoretical value of  $280 \text{ m s}^{-1}$  is 15% less than the experimental value.

The above discrepancy between the observed and calculated values was explained by Laplace in 1816.

Sound travels in air as a longitudinal wave. The wave motion is therefore, accompanied by compressions and rarefactions. At compressions the temperature of air rises and at rarefactions, due to expansion, the temperature decreases. Air is a very poor conductor of heat. Hence at a compression, air cannot lose heat due to radiation and conduction. At a rarefaction it cannot gain heat, during the small interval of time. As a result, the temperature throughout the medium does not remain constant. Laplace suggested that sound waves travel in air under adiabatic condition and not under isothermal condition. For an adiabatic change, the relation between pressure and volume is given by

$$PV^\gamma = \text{constant}$$

Differentiating the equation with respect to  $V$

$$\begin{aligned}
 P \gamma V^{\gamma-1} + V^{\gamma} \frac{dP}{dV} &= 0 \\
 P \gamma + V \frac{dP}{dV} &= 0 \\
 \frac{-dP}{dV/V} &= \gamma P \\
 \therefore B &= \gamma P
 \end{aligned}$$

Thus, for an adiabatic process bulk modulus =  $\gamma P$

Using this value of B we get wave speed

$$v = \sqrt{\frac{B}{\rho}} = \sqrt{\frac{\gamma P}{\rho}}$$

### Factors affecting velocity of sound in gases

#### (i) Effect of pressure

If pressure of the gas is changed keeping its temperature constant,  $P/\rho$  remains constant as the density of gas directly varies as the pressure. Therefore, the speed of sound in a gas does not depend on the pressure of the gas, at constant temperature and constant humidity

Density of water vapour is less than the density of dry air at same temperature. Hence the speed of sound increases with increase in humidity as equation

$$v = \sqrt{\frac{\gamma P}{\rho}}$$

#### (ii) Effect of temperature

For a gas,  $PV = RT$  for one mole of gas

$$P = \frac{RT}{V}$$

Substituting value of P in equation

$$v = \sqrt{\frac{\gamma P}{\rho}}$$

We get

$$v = \sqrt{\frac{\gamma RT}{\rho V}} = \sqrt{\frac{\gamma RT}{m}}$$

Mass of gas is  $m = \rho V$

Speed of sound in gas is directly proportional to the square root of its absolute temperature (T)

$$v \propto \sqrt{T}$$

velocity of sound in air increases by  $0.61 \text{ m s}^{-1}$  per degree centigrade rise in temperature

**(iii) Effect of wind**

The velocity of sound in air is affected by wind. If the wind blows with the velocity  $w$  along the direction of sound, then the velocity of sound increases to  $v + w$ . If the wind blows in the opposite direction to the direction of sound, then the velocity of sound decreases to  $v - w$ . If the wind blows at an angle  $\theta$  with the direction of sound, the effective velocity of sound will be  $(v + w \cos \theta)$ .

**Note:** In a medium, sound waves of different frequencies or wavelengths travel with the same velocity. Hence there is no effect of frequency on the velocity of sound.

### Solved Numerical

Q) The wavelength of a note emitted by a tuning fork of frequency 512 Hz in air at  $17^\circ\text{C}$  is 66.5 cm. If the density of air at S.T.P. is 1.293 g/litre, calculate  $\gamma$  of air

Solution:

Frequency of tuning fork = 512 Hz,  $T = 17 + 273 = 290\text{K}$ ,  $\lambda = 0.665 \text{ m}$

Density of air = 1.293 g/litre =  $1.293 \text{ kg/m}^3$  pressure  $P = 1 \text{ atm} = 1.01 \times 10^5 \text{ N/m}^2$

Velocity of sound  $v = f\lambda = 512 \times 0.665 = 340.5 \text{ m/s}$

$$v = \sqrt{\frac{\gamma P}{\rho}}$$

$$\gamma = \frac{v^2 \rho}{P}$$

$$\gamma = \frac{(340.5)^2 \times 1.293}{1.01 \times 10^5} = 1.48$$

Q) The speed of transverse wave going on a wire having length 50 cm and mass 5.0 g is 80 m/s. The area of cross-section of the wire is  $1.0 \text{ mm}^2$  and its Young's modulus is  $16 \times 10^{11} \text{ N/m}^2$ . Find the extension of the wire over its natural length

Solution:

Length of wire  $L = 50 \text{ cm} = 50 \times 10^{-2} \text{ m}$

Mass of wire  $M = 5 \text{ g} = 5 \times 10^{-3} \text{ kg}$

Cross sectional area of wire  $A = 1 \text{ mm}^2 = 10^{-6} \text{ m}^2$

Young's modulus of wire  $Y = 16 \times 10^{11} \text{ N/m}^2$

Mass per unit length of wire  $m = M/L = 5 \times 10^{-3} \text{ kg} / 50 \times 10^{-2} \text{ m} = 10^{-2} \text{ kg/m}$

The wave speed in wire

$$v = \sqrt{\frac{T}{m}}$$

$$\therefore T = mv^2$$

$$\therefore T = 10^{-2} \times (80)^2 = 64 \text{ N}$$

Now Young's modulus

$$Y = \frac{F/A}{\Delta L/L}$$

Extension of wire  $\Delta L$

$$\Delta L = \frac{FL}{AY}$$

$$\Delta L = \frac{(64)(50 \times 10^{-2})}{(10^{-6})(16 \times 10^{11})} = 0.02 \text{ mm}$$

### Progressive wave

A progressive wave is defined as the onward transmission of the vibratory motion of a body in an elastic medium from one particle to the successive particle.

#### **Equation of a plane progressive wave**

An equation can be formed to represent generally the displacement of a vibrating particle in a medium through which a wave passes.

Thus each particle of a progressive wave executes simple harmonic motion of the same period and amplitude differing in phase from each other.

Let us assume that a progressive wave travels from the origin O along the positive direction of X axis, from left to right

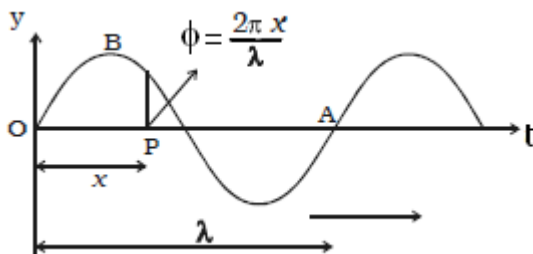

The displacement of a particle at a given instant is  $y = A \sin \omega t$

where  $a$  is the amplitude of the vibration of the particle and  $\omega = 2\pi f$ .

The displacement of the particle P at a distance  $x$  from O at a given instant is given by,  $y = a \sin (\omega t - \phi)$ .

If the two particles are separated by a distance  $\lambda$ , they will differ by a phase of  $2\pi$ . Therefore, the phase  $\phi$  of the particle P at a distance  $x$  is

$$\phi = \frac{2\pi x}{\lambda}$$

$$y = A \sin \left( \omega t - \frac{2\pi x}{\lambda} \right)$$

$$\text{But } k = \frac{2\pi}{\lambda} \text{ wave vector}$$

$$y = A \sin(\omega t - kx) \text{ --- (1)}$$

$$\text{But } \omega = \frac{2\pi}{T}$$

$$y = A \sin \left( \frac{2\pi t}{T} - \frac{2\pi x}{\lambda} \right)$$

$$y = A \sin 2\pi \left( \frac{t}{T} - \frac{x}{\lambda} \right) \text{ --- (2)}$$

If the wave travels in opposite direction, the equation becomes

$$y = A \sin 2\pi \left( \frac{t}{T} + \frac{x}{\lambda} \right)$$

### (i) Variation of phase with time

The phase changes continuously with time at a constant distance. At a given distance  $x$  from O let  $\phi_1$  and  $\phi_2$  be the phase of a particle at time  $t_1$  and  $t_2$  respectively.

$$\phi_1 = 2\pi \left( \frac{t_1}{T} - \frac{x}{\lambda} \right)$$

$$\phi_2 = 2\pi \left( \frac{t_2}{T} - \frac{x}{\lambda} \right)$$

$$\phi_2 - \phi_1 = \frac{2\pi}{T} (t_2 - t_1)$$

$$\Delta\phi = \frac{2\pi}{T} \Delta t$$

This is the phase change  $\Delta\phi$  of a particle in time interval  $\Delta t$ . If  $\Delta t = T$ ,  $\Delta\phi = 2\pi$ . This shows that after a time period  $T$ , the phase of a particle becomes the same

Thus  $d\phi/dt = \text{constant}$

$$\therefore \frac{d}{dt}(\omega t - kx) = 0$$

$$\omega - k \frac{dx}{dt} = 0$$

$$\frac{dx}{dt} = \frac{\omega}{k} = v$$

Here  $v$  is the phase speed of wave. Which is same as speed of wave

### (ii) Variation of phase with distance

At a given time  $t$  phase changes periodically with distance  $x$ . Let  $\phi_1$  and  $\phi_2$  be the phase of two particles at distance  $x_1$  and  $x_2$  respectively from the origin at a time  $t$ .

$$\phi_1 = 2\pi \left( \frac{t}{T} - \frac{x_1}{\lambda} \right)$$

$$\phi_2 = 2\pi \left( \frac{t}{T} - \frac{x_2}{\lambda} \right)$$



$$\varphi_2 - \varphi_1 = -\frac{2\pi}{T}(x_2 - x_1)$$

$$\Delta\varphi = -\frac{2\pi}{T}\Delta x$$

The negative sign indicates that the forward points lag in phase when the wave travels from left to right. When  $\Delta x = \lambda$ ,  $\Delta\varphi = 2\pi$ , the phase difference between two particles having a path difference  $\lambda$  is  $2\pi$

### Characteristics of progressive wave

1. Each particle of the medium executes vibration about its mean position. The disturbance progresses onward from one particle to another.
2. The particles of the medium vibrate with same amplitude about their mean positions.
3. Each successive particle of the medium performs a motion similar to that of its predecessor along the propagation of the wave, but later in time.
4. The phase of every particle changes from 0 to  $2\pi$ .
5. No particle remains permanently at rest. Twice during each vibration, the particles are momentarily at rest at extreme positions, different particles attain the position at different time.
6. Transverse progressive waves are characterised by crests and troughs. Longitudinal waves are characterised by compressions and rarefactions.
7. There is a transfer of energy across the medium in the direction of propagation of progressive wave.
8. All the particles have the same maximum velocity when they pass through the mean position.
9. The displacement, velocity and acceleration of the particle separated by  $m\lambda$  are the same, where  $m$  is an integer.

### Intensity and sound level

The loudness of a sound depends on intensity of sound wave and sensitivity of the ear. The intensity is defined as the amount of energy crossing per unit area per unit time perpendicular to the direction of propagation of the wave.

Intensity is measured in  $\text{W m}^{-2}$ .

The intensity of sound depends on (i) Amplitude of the source ( $I \propto A^2$ ),

(ii) Surface area of the source ( $I \propto S$ ),

(iii) Density of the medium ( $I \propto \rho$ ),

(iv) Frequency of the source ( $I \propto f^2$ ) and

(v) Distance of the observer from the source ( $I \propto 1/r^2$ )

### Solved Numerical

Q) A simple harmonic wave has the equation  $y = 0.3\sin(314t - 1.57x)$ , where  $t$ ,  $x$  and  $y$  are in seconds, meters and cm respectively. Find the frequency and the wavelength of the wave. Another wave has the equation  $y' = 0.10 \sin(314t - 1.57x + 1.57)$ . Deduce the phase difference and the ratio of intensities of wave

Solution:

Since  $y$  is in cm thus given equation in meters unit is

$$y = \frac{0.3}{100} \sin(314t - 1.57x)$$

Comparing with standard equation  $y = a \sin(\omega t - kx)$

We get

$$\omega = 2\pi f = 314$$

Frequency:

$$f = \frac{314}{2 \times 3.14} = 50 \text{ Hz}$$

Wavelength

$$k = \frac{2\pi}{\lambda}$$

$$\lambda = \frac{2\pi}{k} = \frac{2 \times 3.14}{1.57} = 4 \text{ m}$$

Phase difference between two wave is  $(314t - 1.57x + 1.57) - (314t - 1.57x) = 1.57$  radian

Or

$$\frac{1.57 \times 180}{\pi} = 90^\circ$$

The ratio of intensity

$$\frac{I_1}{I_2} = \frac{a_1^2}{a_2^2} = \frac{9}{1}$$

Q) Given the equation for a wave in a string  $y = 0.03\sin(3x - 2t)$

Where  $y$  and  $x$  are in metres and  $t$  is in seconds

- When  $t = 0$ , what is the displacement at  $x = 0.1$  m?
- When  $x = 0.1$  m, what is the displacement at  $t = 0$  and  $t = 0.2$  s?
- What is the equation for the velocity of oscillation of particle of string and what is the maximum velocity
- What is the velocity of propagation of waves

Solution:

Given equation  $y = 0.03\sin(3x - 2t)$

(a) At  $t = 0$ ,  $x = 0.1$  m,  $y = 0.03\sin(0.3) = 8.86 \times 10^{-3}$  m

(b)  $x = 0.1$  m and  $t = 0$   $y = 8.86 \times 10^{-3}$  m

At  $x = 0.1$  at  $t = 0.2$  s

$Y = 0.03\sin(0.3 - 0.4) = -0.03\sin(0.1) \text{ m} = -2.997 \times 10^{-3}$  m

(c) Particle velocity

$$V_P = \frac{dy}{dt} = -0.06 \cos(3x - 2t)$$

$$|V_P|_{\max} = 6 \times 10^{-2} \text{ m/s}$$

$$(d) \text{ Wave velocity} = \omega/k = 2/3 = 0.67 \text{ m/s}$$

### Superposition principle

When two waves travel in a medium simultaneously in such a way that each wave represents its separate motion, then the resultant displacement at any point at any time is equal to the vector sum of the individual displacements of the waves.

Let us consider two simple harmonic waves of same frequency travelling in the same direction. If  $a_1$  and  $a_2$  are the amplitudes of the waves and  $\phi$  is the phase difference between them, then their instantaneous displacements are

$$y_1 = A \sin \omega t$$

$$y_2 = A \sin(\omega t + \phi)$$

According to the principle of superposition, the resultant displacement is represented by

$$y = y_1 + y_2$$

$$= A_1 \sin \omega t + A_2 \sin(\omega t + \phi)$$

$$= A_1 \sin \omega t + A_2 (\sin \omega t \cos \phi + \cos \omega t \sin \phi)$$

$$= (A_1 + A_2 \cos \phi) \sin \omega t + A_2 \sin \phi \cos \omega t \dots(3)$$

$$\text{Put } A_1 + A_2 \cos \phi = A \cos \theta \dots(4)$$

$$A_2 \sin \phi = A \sin \theta \dots(5)$$

Where A and  $\theta$  are constants, then

$$y = A \sin \omega t \cos \theta + A \cos \omega t \sin \theta$$

$$\text{or } y = A \sin(\omega t + \theta) \dots(6)$$

This equation gives the resultant displacement with amplitude A.

From eqn. (4) and (5)

$$A^2 \cos^2 \theta + A^2 \sin^2 \theta = (A_1 + A_2 \cos \phi)^2 + (A_2 \sin \phi)^2$$

$$\therefore A^2 = A_1^2 + A_2^2 + 2A_1A_2 \cos \phi$$

$$A = \sqrt{A_1^2 + A_2^2 + 2A_1A_2 \cos \phi}$$

And

$$\tan \theta = \frac{A_2 \sin \phi}{A_1 + A_2 \cos \phi}$$

We know that intensity is directly proportional to the square of the amplitude

$$I \propto A^2$$

$$\therefore I \propto (A_1^2 + A_2^2 + 2A_1A_2 \cos \phi)$$

### Special cases

The resultant amplitude  $A$  is maximum, when  $\cos \phi = 1$  or  $\phi = 2m\pi$  where  $m$  is an integer (i.e)  $I_{\max} \propto (A_1 + A_2)^2$

The resultant amplitude  $A$  is minimum when

$$\cos \phi = -1 \text{ or } \phi = (2m + 1)\pi$$

$$I_{\min} \propto (A_1 - A_2)^2$$

The points at which interfering waves meet in the same phase

$\phi = 2m\pi$  i.e  $0, 2\pi, 4\pi, \dots$  are points of maximum intensity, where constructive interference takes place.

## Reflection of wave

### Reflection of wave from a rigid support

Suppose a wave propagates in the decreasing value of  $x$ , represented by equation

$$y = A \sin(\omega t + kx) \text{ reaches a point } x = 0$$

When the wave arrives at rigid support, support exerts equal and opposite force on the string. This reaction force generates a wave at the support which travels back (along increasing values of  $x$ ) along the string. This wave is known as reflected wave

At the support  $x = 0$ . Resultant displacement due to incident and reflected wave is zero

Thus if incident wave is

$$y_i = A \sin(\omega t) \text{ since } x = 0$$

then according to superposition principle reflected wave equation at  $x = 0$  is

$$y_r = -A \sin(\omega t)$$

$$\text{or } y_r = A \sin(\omega t + \pi)$$

Above equation shows that during reflection of wave phase increase by  $\pi$

The reflected wave is travelling in positive  $x$  direction so the equation for reflected wave may be written as

$$y_r = A \sin(\omega t + \pi - kx)$$

$$y_r = -A \sin(\omega t - kx)$$

If incident wave equation is  $y_i = A \sin(\omega t - kx)$  the equation for reflected wave is

$$y_r = -A \sin(\omega t + kx)$$

(b) Reflection of waves from a free end:

Suppose one end of the string is tied to a very light ring which can move or slide on the vertical rod without friction. Such end is called free end

Suppose crest reaches such free end then ring moves in upward direction as it is not fixed. As a result phase of reflected wave is same of incident wave. Or phase of reflected and incident wave is same.

If  $y_i = A \sin(\omega t + kx)$  represent incident wave then

$Y_r = -A \sin(\omega t - kx)$  represent reflected wave

## Beats

When two waves of nearly equal frequencies travelling in a medium along the same direction superimpose upon each other, beats are produced. The amplitude of the resultant sound at a point rises and falls regularly.

The intensity of the resultant sound at a point rises and falls regularly with time. When the intensity rises to maximum we call it as waxing of sound, when it falls to minimum we call it as waning of sound.

*The phenomenon of waxing and waning of sound due to interference of two sound waves of nearly equal frequencies are called beats.*

The number of beats produced per second is called beat frequency, which is equal to the difference in frequencies of two waves.

### Analytical method

Let us consider two waves of slightly different frequencies  $f_1$  and  $f_2$  ( $f_1 > f_2$ ) having equal amplitude travelling in a medium in the same direction. At time  $t = 0$ , both waves travel in same phase. The equations of the two waves are

$$y_1 = a \sin 2\pi f_1 t \quad \text{and} \quad y_2 = a \sin 2\pi f_2 t$$

When the two waves superimpose, the resultant displacement is given by

$$y = y_1 + y_2$$

$$y = a \sin (2\pi f_1) t + a \sin (2\pi f_2) t$$

$$y = 2a \sin 2\pi \left( \frac{f_1 + f_2}{2} \right) t \cos 2\pi \left( \frac{f_1 - f_2}{2} \right) t$$

Substituting

$$A = 2a \cos 2\pi \left( \frac{f_1 - f_2}{2} \right) \quad \text{and} \quad f = \frac{f_1 + f_2}{2}$$

$$y = A \sin 2\pi f t$$

This represents a simple harmonic wave of frequency  $f = \frac{f_1 + f_2}{2}$  and amplitude  $A$  which changes with time.

(i) The resultant amplitude is maximum (i.e)  $\pm 2a$ , if

$$\cos 2\pi \left( \frac{f_1 - f_2}{2} \right) = \pm 1$$

$$2\pi \left( \frac{f_1 - f_2}{2} \right) = n\pi$$

(where  $n = 0, 1, 2 \dots$ ) or  $(f_1 - f_2) t = n$

The first maximum is obtained at  $t_1 = 0$

The second maximum is obtained at

$$t_2 = \frac{1}{f_1 - f_2}$$

The third maximum at

$$t_3 = \frac{2}{f_1 - f_2}$$

and so on.

The time interval between two successive maxima is

$$t_2 - t_1 = t_3 - t_2 = 1 / (f_1 - f_2)$$

Hence the number of beats produced per second is equal to the reciprocal of the time interval between two successive maxima.

(ii) The resultant amplitude is minimum (i.e) equal to zero, if

$$\begin{aligned} \cos 2\pi \left( \frac{f_1 - f_2}{2} \right) &= 0 \\ 2\pi \left( \frac{f_1 - f_2}{2} \right) &= \frac{\pi}{2} + n\pi \\ (f_1 - f_2)t &= \frac{2n + 1}{2} \end{aligned}$$

where  $n = 0, 1, 2 \dots$

The first minimum is obtained at  $n = 0$

$$t'_1 = \frac{1}{2(f_1 - f_2)}$$

The second minimum is obtained at  $n = 1$

$$t'_2 = \frac{2}{2(f_1 - f_2)}$$

The third minimum is obtained at

$$t'_3 = \frac{5}{2(f_1 - f_2)}$$

Time interval between two successive minima is

$$t'_2 - t'_1 = t'_3 - t'_2 = \frac{1}{f_1 - f_2}$$

Hence, the number of beats produced per second is equal to the reciprocal of time interval between two successive minima.

### **Uses of beats**

(i) The phenomenon of beats is useful in tuning two vibrating bodies in unison. For example, a sonometer wire can be tuned in unison with a tuning fork by observing the beats. When an excited tuning fork is kept on the sonometer and if the sonometer wire is also excited, beats are heard, when the frequencies are nearly equal. If the length of the wire is adjusted carefully so that the number of beats gradually decreases to zero, then the two are said to be in unison. Most of the musical instruments are made to be in unison based on this method.

(ii) The frequency of a tuning fork can be found using beats. A standard tuning fork of frequency  $N$  is excited along with the experimental fork. If the number of beats per second is  $n$ , then the frequency of experimental tuning fork is  $N+n$ . The experimental tuning fork is then loaded with a little bees' wax, thereby decreasing its frequency. Now the observations are repeated. If the number of beats increases, then the frequency of the experimental tuning fork is  $N-n$ , and if the number of beats decreases its frequency is  $N + n$ .

### Solved Numerical

Q) Two wires are fixed on a sonometer. Their tensions are in ratio 8:1, the lengths in the ratio 36:35, the diameters in the ratio 4:1, the densities in the ratio 1:2. Find the frequency of beats if the note of higher pitch has a frequency of 360Hz.

Solution:

$$v = \sqrt{\frac{T}{m}}$$

$T$  is tension and  $m$  is mass of string per unit length

$$v = \sqrt{\frac{T}{\left(\frac{\pi d^2}{4}\right) \rho}}$$

$$\frac{v_1}{v_2} = \sqrt{\frac{T_1 d_2^2 \rho_2}{T_2 d_1^2 \rho_1}} = \sqrt{\left(\frac{8}{1}\right) \left(\frac{1}{16}\right) \left(\frac{2}{1}\right)} = 1$$

Thus  $v_1 = v_2 = v$  (say)

$$f_1 = \frac{v}{2L_1} = 360 - x$$

$$f_2 = \frac{v}{2L_2} = 360$$

$$\frac{360 - x}{360} = \frac{L_2}{L_1} = \frac{35}{36}$$

$$360 - x = 350$$

$$x = 10 \text{ beats}$$

Q) A wire of a sonometer 1m long weight 5g and is stretched by a force of 10kg wt. When the length of the vibrating portion of wire is 28 cm three beats per second are heard, if the wire and unknown frequency are sound together. The wire is slightly shorted and 4 beats per second are then heard. What is the frequency of the fork?

Solution:

The frequency of the sonometer wire

$$f_1 = \frac{1}{2L} \sqrt{\frac{T}{m}}$$

$$L = 0.28\text{m}, T = 10 \times 9.8 = 98 \text{ N}, m = 5\text{gm} = 5 \times 10^{-3} \text{ kg/m}$$

$$f_1 = \frac{1}{2 \times 0.28} \sqrt{\frac{98}{5 \times 10^{-3}}} = 250\text{Hz}$$

The sonometer wire has a frequency which differs from the tuning fork by 3Hz.

If the wire is shorted, the frequency of the wire increases. The number of beats also increases to 4.

This means that the frequency of the wire is greater than the frequency of the tuning fork

$\therefore$  the frequency of the tuning fork =  $250 - 3 = 247 \text{ Hz}$

### Stationary waves

When two progressive waves of same amplitude and wavelength travelling along a straight line in opposite directions superimpose on each other, stationary waves are formed.

#### Analytical method

Let us consider a progressive wave of amplitude  $a$  and wavelength  $\lambda$  travelling in the direction of X axis.

$$y_1 = a \sin 2\pi \left( \frac{t}{T} - \frac{x}{\lambda} \right)$$

This wave is reflected from a **free end** and it travels in the negative direction of X axis, then

$$y_2 = a \sin 2\pi \left( \frac{t}{T} + \frac{x}{\lambda} \right)$$

According to principle of superposition, the resultant displacement is  $y = y_1 + y_2$

$$y = a \left[ \sin 2\pi \left( \frac{t}{T} - \frac{x}{\lambda} \right) + \sin 2\pi \left( \frac{t}{T} + \frac{x}{\lambda} \right) \right]$$

$$y = a \left[ 2 \sin \frac{2\pi t}{T} \cos \frac{2\pi x}{\lambda} \right]$$

$$y = 2a \cos \frac{2\pi x}{\lambda} \sin \frac{2\pi t}{T}$$

This is the equation of a stationary wave.

(i) At points where  $x = 0, \lambda/2, \lambda, 3\lambda/2$  the values of

$$\cos \frac{2\pi x}{\lambda} = \pm 1$$

$\therefore A = + 2a$ . At these points the resultant amplitude is maximum. They are called *antinodes* (Fig.).

(ii) At points where  $x = \lambda/4, 3\lambda/4, 5\lambda/4$  the values of



$$\cos \frac{2\pi x}{\lambda} = 0$$

$\therefore A = 0$ . At these points the resultant amplitude is minimum. They are called *nodes* (Fig.).

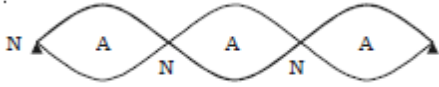

The distance between any two successive antinodes or nodes is equal to  $\lambda/2$  and the distance between an antinode and a node is  $\lambda/4$

(iii) When  $t = 0, T/2, T, 3T/2, \dots$

$$\sin \frac{2\pi t}{T} = 0$$

Displacement is zero

(iv) When  $t = T/4, 3T/4, 5T/4, \dots$

$$\sin \frac{2\pi t}{T} = \pm 1$$

Displacement is maximum

### **Characteristics of stationary waves**

1. The waveform remains stationary.
2. Nodes and antinodes are formed alternately.
3. The points where displacement is zero are called nodes and the points where the displacement is maximum are called antinodes.
4. Pressure changes are maximum at nodes and minimum at antinodes.
5. All the particles except those at the nodes, execute simple harmonic motions of same period.
6. Amplitude of each particle is not the same, it is maximum at antinodes decreases gradually and is zero at the nodes.
7. The velocity of the particles at the nodes is zero. It increases gradually and is maximum at the antinodes.
8. Distance between any two consecutive nodes or antinodes is equal to  $\lambda / 2$  whereas the distance between a node and its adjacent antinode is equal to  $\lambda/4$ .
9. There is no transfer of energy. All the particles of the medium pass through their mean position simultaneously twice during each vibration
10. Particles in the same segment vibrate in the same phase and between the neighboring segments, the particles vibrate in opposite phase.

**Modes of vibration of stretched string****(i) Fundamental frequency**

If a wire is stretched between two points, a transverse wave travels along the wire and is reflected at the fixed end. A transverse stationary wave is thus formed as shown in Fig. When a wire AB of length L is made to vibrate in one segment then

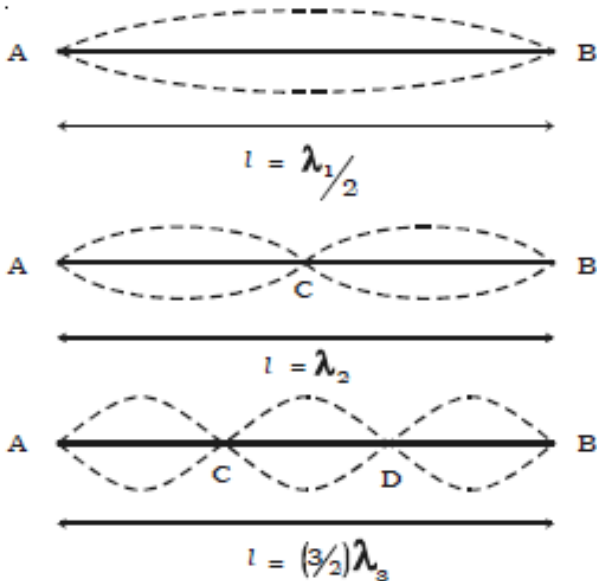

$$L = \frac{\lambda_1}{2}$$

$\lambda_1 = 2L$ . This gives the lowest frequency called fundamental frequency

$$f_1 = \frac{v}{\lambda_1}$$

We know that velocity of wave in stretched string is given by  $v = \sqrt{\frac{T}{m}}$

$$f_1 = \frac{1}{2L} \sqrt{\frac{T}{m}}$$

**(ii) Overtones in stretched string**

If the wire AB is made to vibrate in two segments then  $L = \lambda_2$

But

$$f_2 = \frac{v}{\lambda_2}$$

$$f_2 = \frac{1}{L} \sqrt{\frac{T}{m}}$$

$f_2$  is the frequency of the first overtone.

Since the frequency is equal to twice the fundamental, it is also known as second harmonic.

Similarly, higher overtones are produced, if the wire vibrates with more segments.

If there are  $n$  segments, the length of each segment is

$$\lambda_n = \frac{2L}{n}$$

Frequency  $f_n$

$$f_n = \frac{n}{2L} \sqrt{\frac{T}{m}} = n f_1$$

(i.e)  $n^{\text{th}}$  harmonic corresponds to  $(n-1)^{\text{th}}$  overtone

**Laws of transverse vibrations of stretched strings**

The laws of transverse vibrations of stretched strings are

(i) the law of length

For a given wire ( $m$  is constant), when  $T$  is constant, the fundamental frequency of vibration is inversely proportional to the vibrating length (i.e)

$$f \propto \frac{1}{L} \quad \text{or } fL = \text{constant}$$

(ii) law of tension

For constant  $L$  and  $m$ , the fundamental frequency is directly proportional to the square root of the tension (i.e)  $n \propto \sqrt{T}$ .

(iii) the law of mass.

For constant  $L$  and  $T$ , the fundamental frequency varies inversely as the square root of the mass per unit length of the wire (i.e)  $n \propto 1/\sqrt{m}$

**Vibrations of air column in pipes**

Musical wind instruments like flute, clarinet etc. are based on the principle of vibrations of air columns. Due to the superposition of the incident wave and the reflected wave, longitudinal stationary waves are formed in the pipe.

**Organ pipes**

Organ pipes are musical instruments which are used to produce musical sound by blowing air into the pipe. Organ pipes are two types (i) closed organ pipes, closed at one end (ii) open organ pipe, open at both ends.

**(i) Closed organ pipe :** If the air is blown lightly at the open end of the closed organ pipe, then the air column vibrates (Fig.a) in the fundamental mode. There is a node at the closed end and an antinode at the open end. If  $L$  is the length of the tube,  $\lambda_1 = 4L$



$$\lambda_1 = 4L$$

(a)

If  $f_1$  is the fundamental frequency of the vibrations and  $v$  is the velocity of sound in air, then

$$f_1 = \frac{v}{\lambda_1} = \frac{v}{4L}$$

If air is blown strongly at the open end, frequencies higher than fundamental frequency can be produced. They are called overtones.

b & c shows the mode of vibration with two or more nodes and antinodes

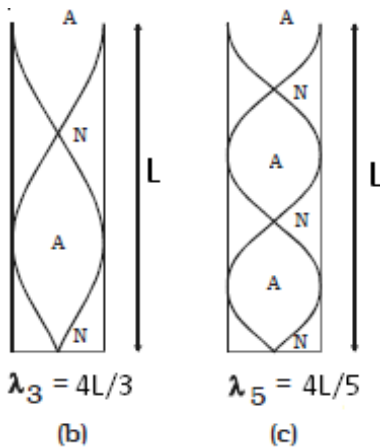

$$L = 3\lambda_3/4 \text{ or } \lambda_3 = 4L/3$$

$$\therefore f_3 = \frac{v}{\lambda_3} = \frac{3v}{4L} = 3f_1$$

This is the first overtone or third harmonics

Similarly

$$f_5 = \frac{5v}{4L} = 5f_1$$

This is the second overtone or fifth harmonic

### Solved Numerical

Q) A disc contains 30 small holes evenly distributed along the rim and is rotated at the uniform rate of 540 revolutions per minute. A jet of air is blown through the hole in to a pipe whose other end is closed by movable piston. The length of the pipe can be varied between 90cm to 120 cm. What should be the exact length of the pipe so that the sound produced at the frequency on interruption of air jet is loudest? ( velocity of sound in air =330 m/s)

Solution:

The frequency of notes produced by the disc = number of holes  $\times$  frequency of rotating disc

$$f = 60 \times \frac{540}{60} = 270 \text{ Hz}$$

This note is produced at the mouth of the closed pipe

Let us first assume that closed pipe is vibrates in its fundamental mode

Then fundamental frequency

$$f_1 = \frac{v}{4L}$$

$$L = \frac{v}{4f_1}$$

$$L = \frac{330}{4 \times 270} = 0.306m = 30.6 \text{ cm}$$

This length is much shorter than the length given

The same fundamental frequency can also occur at a length

From the formula for first overtone

$$f_3 = \frac{3v}{4L}$$

if length is changed from L to 3L then we get

$$f = \frac{3v}{4(3L)} = \frac{v}{4L} = f_1$$

Thus the same fundamental frequency can also occur at a length  $3 \times 30.6 = 91.8 \text{ cm}$ . This is greater than the minimum length 90cm of tube. The tube should be adjusted to this length to get the loudest note as desired

Note: If in place of air if any other gas is used then calculate velocity of sound in that gas and used in place of v to determine length

**(ii) Open organ pipe –**

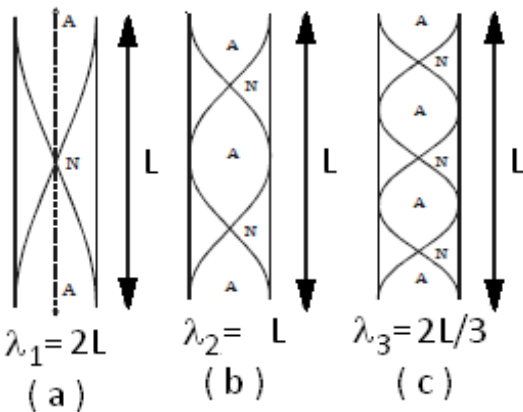

When air is blown into the open organ pipe, the air column vibrates in the fundamental mode Fig.a. Antinodes are formed at the ends and a node is formed in the middle of the pipe. If L is the length of the pipe, then  $\lambda_1 = 2L$

$$v = f_1 \lambda_1 = f_1 2L$$

The fundamental frequency

$$f_1 = \frac{v}{2L}$$

In the next mode of vibration additional nodes and antinodes are formed as shown in fig(b) and fig(c)

$$L = \lambda_2 \text{ or } v = f_2 \lambda_2 = f_2 L$$

$$f_2 = \frac{v}{L} = 2f_1$$

Similarly,

$$f_3 = \frac{v}{\lambda_3} = \frac{3v}{2L} = 3f_1$$

This is the second overtone or third harmonic.

Therefore the frequency of nth overtone is  $(n + 1) f_1$  where  $f_1$  is the fundamental frequency. The frequencies of harmonics are in the ratio of 1 : 2 : 3 ....

## Solved Numerical

Q) An open pipe filled with air has a fundamental frequency of 500Hz. The first harmonic of another organ pipe closed at one end and filled with carbon dioxide has the same frequency as that of the first harmonic of the open organ pipe. Calculate the length of each pipe. Assume that the velocity of sound in air and in carbondioxide to be 330 m/s and 264 m/s respectively

Solution:

The fundamental frequency is the first harmonics. In case of open pipe containing air at 30°C. Let  $L_o$  be the length of the pipe. Then

$$f_1 = \frac{v}{2L_o}$$

$$L_o = \frac{v}{2f}$$

$$L_o = \frac{330}{2 \times 500} = 33 \text{ cm}$$

Let  $L_c$  be the length of the closed pipe. For the fundamental frequency of the ipipe

$$f_1 = \frac{v_{CO_2}}{4L_c}$$

$$L_c = \frac{264}{4 \times 500} = 13.2 \text{ cm}$$

**Resonance air column apparatus**

The glass tube is mounted on a vertical stand with a scale attached to it. The glass tube is partly filled with water. The level of water in the tube can be adjusted by raising or lowering the reservoir.

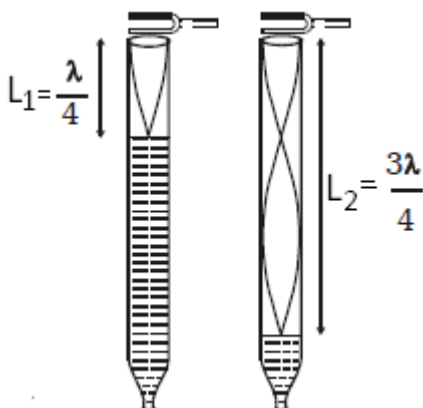

A vibrating tuning fork of frequency  $f$  is held near the open end of the tube.

The length of the air column is adjusted by changing the water level. The air column of the tube acts like a closed organ pipe.

When this air column resonates with the frequency of the fork the intensity of sound is maximum.

Here longitudinal stationary wave is formed with node at the water surface and an antinode near the open end. If  $L_1$

is the length of the resonating air column

$$\frac{\lambda}{4} = L_1 + e \quad \text{--- eq(1)}$$

where  $e$  is the end correction.

The length of air column is increased until it resonates again with the tuning fork. If  $L_2$  is the length of the air column

$$\frac{3\lambda}{4} = L_2 + e \quad \text{--- eq(2)}$$

From equations (1) and (2)

$$\frac{\lambda}{2} = L_2 - L_1$$

The velocity of sound in air at room temperature

$$v = f\lambda = 2f(L_2 - L_1)$$

### **End correction**

The antinode is not exactly formed at the open end, but at a small distance above the open end. This is called the end correction

It is found that  $e = 0.61r$ , where  $r$  is the radius of the glass tube.

### Doppler Effect

When a sound source and an observer are in relative motion with respect to the medium in which the wave propagate, the frequency of wave observed is different from the frequency of sound emitted by the source. This phenomenon is called Doppler effect. This is due to the wave nature of sound propagation and is therefore applicable to light waves also.

Calculation of apparent frequency

Suppose  $V$  is the velocity of sound in air,  $V_o$  is the velocity of observer (O) and  $f$  is the frequency of the source

#### **(i) Source moves towards stationary observer**

If the source  $S$  were stationary, the  $f$  waves sent out in one second towards the observer  $O$  would occupy a distance  $V$  and the wave length would be  $v/f$

If  $S$  is moving with velocity  $V_s$  towards stationary observer, the  $f$  waves emitted in one second occupy a distance  $(V - V_s)$  because  $S$  has moved a distance  $V_s$  towards  $O$  in 1 sec.. So apparent frequency would be

$$\lambda' = \left( \frac{V - V_s}{f} \right)$$

$\therefore$  apparent frequency

$$f' = \frac{\text{velocity of sound relative to } O}{\text{wavelength of wave reaching } O}$$

$$f' = \frac{V}{\lambda'} = f \left( \frac{V}{V - V_s} \right)$$

#### **(ii) Source moves away from stationary observer:**

Apparent wave length

$$\lambda' = \left( \frac{V + V_s}{f} \right)$$

$$f' = \frac{V}{\lambda'} = f \left( \frac{V}{V + V_s} \right)$$

**(iii) Observer moving towards stationary source**

$$f' = \frac{\text{velocity of sound relative to } O}{\text{wavelength of wave reaching } O}$$

Velocity of sound relative to O = V + V<sub>o</sub>

And wavelength of waves reaching O = V/f

$$f' = \frac{V + V_o}{V/f} = f \left( \frac{V + V_o}{V} \right)$$

**(iv) Observer moves away from the stationary source:**

Velocity of sound relative to O = V - V<sub>o</sub>

And wavelength of waves reaching O = V/f

$$f' = \frac{V - V_o}{V/f} = f \left( \frac{V - V_o}{V} \right)$$

**(v) Source and observer both moves towards each other**

Velocity of sound relative to O = V + V<sub>o</sub>

And wavelength of waves reaching O = (V - V<sub>s</sub>)/f

$$f' = \frac{V + V_o}{\frac{V - V_s}{f}} = f \left( \frac{V + V_o}{V - V_s} \right)$$

**(vi) Source and observer both are moving away from each other**

Velocity of sound relative to O = V - V<sub>o</sub>

And wavelength of waves reaching O = (V + V<sub>s</sub>)/f

$$f' = \frac{V - V_o}{\frac{V + V_s}{f}} = f \left( \frac{V - V_o}{V + V_s} \right)$$

**(vii) Source moves towards observer but observer moves away from source**

Velocity of sound relative to O = V - V<sub>o</sub>

And wavelength of waves reaching O = (V + V<sub>s</sub>)/f

$$f' = \frac{V - V_o}{\frac{V + V_s}{f}} = f \left( \frac{V - V_o}{V + V_s} \right)$$

**(viii) Source moves away from observer but observer moves towards source**

Velocity of sound relative to O = V + V<sub>o</sub>

And wavelength of waves reaching O = (V - V<sub>s</sub>)/f



$$f' = \frac{V + V_0}{\frac{V + V_s}{f}} = f \left( \frac{V + V_0}{V + V_s} \right)$$

General equation can be written as

$$f' = f \left( \frac{V \pm V_o}{V \pm V_s} \right)$$

If **observer** moving **towards** source  $V_o$  is +Ve

If **observer** moving **away** from source  $V_o$  is -Ve

If **source** is moving **towards** or approaching observer  $V_s$  is -Ve

If **source** moving **away** from observer  $V_s$  is +Ve

### Effect of wind velocity

If wind velocity ( $w$ ) is in the direction of sound ( $v$ ) then we can add wind velocity

If wind velocity ( $w$ ) is opposite in the direction of sound we can subtract wind velocity for final velocity of sound

### Doppler effect when the source is moving at an angle to the observer

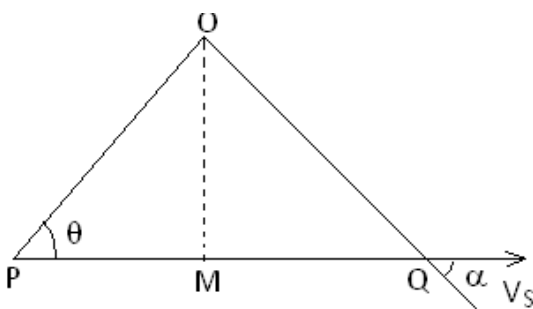

Let O be a stationary observer and let a source of sound of frequency  $f$  be moving along the line PQ with constant speed  $v_s$

When the source is at O, the line PO makes angle  $\theta$  with PQ, which is the direction of  $v_s$

The component of velocity  $v_s$  along PO is  $v_s \cos \theta$  and it is towards the observer

The apparent frequency in this case

$$f_a = f \left( \frac{V}{V - v_s \cos \theta} \right)$$

As the source moves along PQ,  $\theta$  increases  $\cos \theta$  decreases and the apparent frequency continuously diminishes. At M,  $\theta = 90^\circ$  and hence  $f_a = f$

When the source is at Q, the component of velocity  $v_s$  is  $v_s \cos \alpha$  which is directed away from the observer. Hence the apparent frequency

$$f_a = f \left( \frac{V}{V + v_s \cos \alpha} \right)$$

### Solved Numerical

Q) A train travelling at a speed of 20 m/s and blowing a whistle with frequency of 240 Hz is approaching a train B which is at rest. Assuming the speed of sound to be 340 m/s calculate the following

(a) Wavelength in air (i) in front and (ii) behind the train A

(b) Frequencies measured by a listener in train B while train A is (i) approaching and (ii) receding from train B

(c) If train B starts moving with speed of 10 m/s, what will be the frequencies heard by a passenger in train B if both were (i) approaching and (ii) receding

Solution:

(a)(i) The train A is approaching the train B which is at rest

Thus  $V_o = 0$ , since source is approaching thus  $V_s$  is -ve

$$f' = f \left( \frac{V \pm V_o}{V \pm V_s} \right)$$

$$f' = f \left( \frac{V}{V - V_s} \right)$$

Now  $f = V/\lambda$

$$\therefore \frac{V}{\lambda'} = \frac{V}{\lambda} \left( \frac{V}{V - V_s} \right)$$

$$\therefore \lambda' = \lambda \left( \frac{V - V_s}{V} \right) = \frac{\lambda}{V} (V - V_s)$$

$$\therefore \lambda' = \frac{1}{f} (V - V_s)$$

$$\therefore \lambda' = \frac{1}{240} (340 - 20) = 1.33 \text{ m}$$

(ii) For observer behind the train A since source is moving away  $V_s$  is positive Thus

$$\therefore \lambda' = \frac{1}{f} (V + V_s)$$

$$\therefore \lambda' = \frac{1}{240} (340 + 20) = 1.5 \text{ m}$$

(b)(i) Frequency as measured by listener on train B when A is approaching B

Source is approaching  $V_s$  is -ve, Listener is stationary  $V_o = 0$

$$f' = f \left( \frac{V \pm V_o}{V \pm V_s} \right)$$

$$\therefore f' = f \left( \frac{V}{V - V_s} \right)$$

$$\therefore f' = 240 \left( \frac{340}{340 - 20} \right) = 255 \text{ Hz}$$

(ii) Frequency as measured by listener in B as A recedes from him

Source moving away  $V_s$  is +ve, Listener is stationary  $V_o = 0$

$$f' = f \left( \frac{V \pm V_o}{V \pm V_s} \right)$$

$$\therefore f' = f \left( \frac{V}{V + V_s} \right)$$

$$\therefore f' = 240 \left( \frac{340}{340 + 20} \right) = 227 \text{ Hz}$$

(C)(i) Now both the trains are approaching each other  
observer moving towards source  $V_o$  is +Ve and  
Source is approaching  $V_s$  is -Ve

$$f' = f \left( \frac{V + V_o}{V - V_s} \right)$$

$$\therefore f' = f \left( \frac{V + V_o}{V - V_s} \right)$$

$$\therefore f' = 240 \left( \frac{340 + 10}{340 - 20} \right) = 263 \text{ Hz}$$

(ii) Now both trains are moving away  
observer moving away source  $V_o$  is -Ve and  
Source is moving away  $V_s$  is +Ve

$$f' = f \left( \frac{V + V_o}{V - V_s} \right)$$

$$\therefore f' = f \left( \frac{V - V_o}{V + V_s} \right)$$

$$\therefore f' = 240 \left( \frac{340 - 10}{340 + 20} \right) = 220 \text{ Hz}$$

Q) A spectroscope examination of light from a certain star shows that the apparent wavelength of certain spectral line from a certain star is  $5001 \text{ \AA}$ . Whereas the observed wavelength of the same line produced by terrestrial source is  $5000$ . In what direction and what speed do these figure suggest that the star is moving relative to the earth.

Solution:

Actual wavelength of the spectral line =  $5000 \text{ \AA}$

Apparent wave length of the same line =  $5001 \text{ \AA}$

Since wavelength increases, the star is moving away from earth ( red shif)  $V_s$  is positive

Observer is stationary and velocity of light  $V = c$

$$f' = f \left( \frac{V \pm V_o}{V \pm V_s} \right)$$

$$f' = f \left( \frac{c}{c + V_s} \right)$$

$$\frac{c}{\lambda'} = \frac{c}{\lambda} \left( \frac{c}{c + V_s} \right)$$

$$\lambda' = \lambda \left( \frac{c + V_s}{c} \right)$$

$$V_s = \frac{\lambda' c}{\lambda} - c$$

$$V_s = c \left( \frac{\lambda' - \lambda}{\lambda} \right)$$

$$V_s = 3 \times 10^8 \left( \frac{10^{-10}}{5000 \times 10^{-10}} \right) = 6 \times 10^4 \text{ m/s}$$

Q) A whistle of frequency 1000 Hz is blown continuously in front of a board made of plaster of paris. If the board is made to move away from the whistle with a velocity of 1.375 m/s, calculate the number of beats heard per second by a stationary observer situated in front of the board in line with the whistle ( velocity of sound in air = 330 m/s)

Solution

The frequency of whistle = 1000Hz

The reflecting board is moving away from the whistle with velocity of 1.375 m/s

The reflected source of sound for the observer is the image of the whistle behind the board, the image is moving away from the board with velocity  $2 \times 1.375 = 2.750$  m/s

Therefore the frequency of sound heard by the observer due to reflection from the board is

$$f' = f \left[ \frac{V}{V + V_s} \right]$$

$$f' = 1000 \left[ \frac{330}{330 + 2.75} \right] = 992 \text{ (approx)}$$

$\therefore$  number of beats heard by the observer =  $1000 - 992 = 8$  per second

-----END-----

To become a member of [www.gneet.com](http://www.gneet.com) give call on +9109737240300