

ELECTRIC CURRENT

Electric current:

The net amount of charge flowing through a cross section in unit time is defined as current.

Mathematical Equation: If rate of flow of charge is independent of time, then the electric current is said to be steady then $I = Q/t$

If rate of flow of charge varies with time, the current at any time i.e. instantaneous current is given by $I = dQ/dt$.

If n be the number of conduction electrons crossing cross-section in time t then $I = ne/t$.
SI unit of current is ampere.

One ampere is defined as If one coulomb of charge flows across any of its cross-section in one second.

Note: Electric current has direction as well as magnitude but it is not a vector quantity. This is because currents do not add like vectors.

Solved Numerical

Q) An electric device sends out 78 coulombs of charge through a conductor in 6 seconds. Find current flow

Solution

Given $Q = 78C$, time of flow $t = 6s$

The current $I = Q/t = 78/6 = 13A$

Q) What is the quantity of electricity required to provide a current of 10A for one hour

Solution

Given current $I = 10A$, time of flow $t = 1 \text{ hour} = 3600s$

The quantity of electricity = amount of charge flowing

$Q = It$

$Q = (10)(3600) = 36000C$

Q) The current through a wire varies with time as $I = I_0 + \alpha t$, where $I_0 = 10A$ and $\alpha = 4 A/s$. Find the charge that flows across a cross-section of the wire in first 10 seconds

Solution:

Current $I = dq/dt = I_0 + \alpha t$

$dq = (I_0 + \alpha t)dt$

Integrating on both sides

$$\int dq = \int_{t=0}^{t=10} (I_0 + \alpha t) dt$$

$$q = \left[I_0 t + \frac{\alpha t^2}{2} \right]_{t=0}^{t=10}$$

$$q = 10I_0 + 50\alpha$$

substituting $I_0 = 10$ and $\alpha = 4$

$$q = 10(10) + 50(4) = 300C$$

Ohm's Law:

The current which flows in conductor is proportional to the potential difference which causes its flow at constant temperature and pressure.

Thus $V = IR$.

where the constant R is the resistance of conductor.

Unit of resistance is Ohm denoted as Ω .

Resistance:

Formula for resistance is $R = \rho \frac{l}{A}$

Here l is length of conductor, A is area of cross-section of conductor and ρ is resistivity of conductor.

Resistivity of conductor is independent of size and shape of conductor, it depends on material of conductor and temperature and pressure.

Unit of resistivity is Ohm-m.

Inverse of resistivity is conductivity denoted by σ unit is $(\text{Ohm-m})^{-1}$

Solved Numerical

Q) Calculate the electrical resistivity of the material of wire of length 200cm, area of cross-section 2cm^2 and of resistance $5 \times 10^{-4} \Omega$

Solution

$$R = \rho \frac{l}{A}$$

$$\rho = \frac{RA}{l} = \frac{5 \times 10^{-4} \times 2 \times 10^{-4}}{2} = 5 \times 10^{-8} \Omega m$$

Q) A wire of resistance 5Ω is drawn out so that its new length is three times its original length. Find the resistance of the longer wire. What would be the effect on resistivity?

Solution:

Resistivity will not change, as it does not depend on length and cross-sectional area

Resistance of longer wire can be calculated as follows

Since volume of wire is not changed therefore

$$Al = A'l'$$

$$\text{Now } l' = 3l$$

$$Al = (3l)l' \text{ thus } A' = A/3$$

New resistance

$$R' = \rho \frac{l'}{A'} = \rho \frac{3l}{A/3} = \rho \frac{l}{A} 9 = 9R$$

Old length resistance $R = 5 \Omega$, thus new resistance = 45Ω

Current density:From equation $V = IR$

$$V = I\rho \frac{l}{A} = \rho J l$$

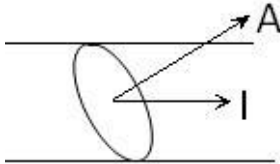
Here J is current density defined as current per unit area (taken normal to the current) $J = I/A$. SI unit of current density is A/m^2 .If there is angle between direction of current and area vector of cross section is θ Then current density $J = I / A \cos\theta$

Relation between Current density and Electric field .

For formula $V = IR$

$$V = I\rho \frac{l}{A} = \rho J l$$

$$\frac{V}{l} = \rho J$$

But $E = \frac{V}{l}$

$$E = \rho J \quad \text{or} \quad J = \sigma E$$

Solved NumericalQ) An electron beam has an aperture of $10^{-6} m^2$. The total number of electrons moving through any perpendicular cross-section per second is 6.0×10^{16} . Calculate the current density of beam.

Solution:

$$J = \frac{I}{A} = \frac{Q}{At} = \frac{ne}{At}$$

$$J = \frac{6 \times 10^{16} \times 1.6 \times 10^{-19}}{10^{-6} \times 1} = 9.6 \times 10^3 Am^{-2}$$

Q) A current of 4.8 ampere is flowing in a copper wire of cross sectional area $3 \times 10^{-4} m^2$. Find the current density of in the wire

Solution:

$$J = \frac{4.8}{3 \times 10^{-4}} = 1.6 \times 10^4 Am^{-2}$$

Origin of resistivity:

In metallic conductors, the electrons in the outer shells are less bounded with the nucleus. Due to thermal energy at room temperature, such valence electrons are liberated from atom leaving behind positively charged ions. These ions are arranged in a regular geometric arrangement on lattice points. These liberated electrons collide with the ions. Or constantly gets scattered from its path causing resistivity of metallic conductors.

Drift of electrons:

In absence of electric field electrons move in randomly after colliding with ions and direction and velocities of electrons after collisions is such that sum of velocities is zero and net charge passing through any cross section is zero causing no electric current. In presence of electric field (E) electrons experiences electric force of magnitude Ee in the direction opposite to the direction of electric field thus the acceleration of electron is opposite to direction of electric field. Now $F = ma$ thus acceleration of electron $a = Ee/m$ this acceleration is momentary and becomes zero after collision, since electrons are continuously colliding with ions. And electrons get accelerated again and process goes of repeating.

As a result electrons are dragged in the opposite to the electric field. Now average time period between two successive collisions is known as relaxation time τ . And corresponding average velocity of electrons is known as drift velocity v_d .

Now $v_d = a\tau$

$$v_d = \frac{Ee}{m}\tau$$

Relation between drift velocity and current density

Let us consider a cylindrical conductor of cross section A . Let E be the electric field exists in conductor.

If v_d is drift velocity of electrons then volume of the electrons passing through a cross-section in one second = $v_d A$.

If n is the number of electrons per unit volume then $nv_d A$ is the number of electron in passing through a cross-section in one second.

Net charge passing through a cross-section in one second = $neAv_d = I$.

Now $I = neAv_d$.

Thus $J = nev_d$

Relation between resistivity and relaxation time.

We know that $J = \sigma E$, here σ is conductivity

And $J = nev_d$

$nev_d = \sigma E$

Substituting value of $v_d = \frac{Ee}{m}\tau$ in above equation we get

$$\sigma E = ne \frac{Ee}{m} \tau$$

$$\sigma = \frac{ne^2}{m} \tau$$

Since $\sigma = 1/\rho$

$$\rho = \frac{m}{ne^2\tau}$$

Here we have assumed that τ and n are constant.

On increasing temperature of conductor n does not change appreciable. The oscillations of ions increases with temperature and becomes more erratic. As a result, the relaxation time (τ) decreases and resistivity of conductor increases with increase in temperature

Solved Numerical

Q) Estimate the average drift speed of conduction electrons in a copper wire of cross sectional area $1.0 \times 10^{-7} \text{ m}^2$ carrying a current of 1.5A. Assume that each copper atom contributes roughly one conduction electron. The density of copper is $9.0 \times 10^3 \text{ kgm}^{-3}$ and its atomic mass is 63.5u.

Solution

Given : weight of 1 m^3 volume of copper is $9.0 \times 10^3 \text{ kg}$ or $9.0 \times 10^6 \text{ gm}$:

Now 63.5 gm of copper contains N_A (Avogadro's number 6.23×10^{23}) of atoms Thus $9.0 \times 10^6 \text{ gm}$ of copper contains

$$\frac{9.0 \times 10^6 \times 6.23 \times 10^{23}}{63.5} = 8.8 \times 10^{28} \text{ atoms/m}^3$$

each copper atom is assumed to contribute one atom one electron .

So number density $n = 8.8 \times 10^{28} / \text{m}^3$

$A = 1.0 \times 10^{-7} \text{ m}^2$, $I = 1.5 \text{ A}$, $e = 1.6 \times 10^{-19} \text{ C}$

from formula for drift velocity

$$v_d = \frac{I}{neA}$$

$$v_d = \frac{1.5}{8.8 \times 10^{28} \times 1.6 \times 10^{-19} \times 1.0 \times 10^{-7}} = 1.065 \times 10^{-3} \text{ m/s}$$

$$V_d = 1.065 \text{ mm/s}$$

Q) A potential difference of 100V is applied to the ends of a copper wire one metre long. Calculate the average drift velocity of the electrons. Compare it with thermal velocity at 27°C . conductivity of copper = $5.81 \times 10^7 \Omega^{-1}\text{m}^{-1}$, $n = 8.5 \times 10^{28}$

Solution :

$$E = V/l = 100/1 = 100 \text{ V/m}$$

$$J = \sigma E$$

$$\text{Now } J = neV_d$$

$$\sigma E = neV_d$$

$$v_d = \frac{\sigma E}{ne} = \frac{5.81 \times 10^7 \times 100}{8.5 \times 10^{28} \times 1.6 \times 10^{-19}} = 0.43 \text{ m/s}$$

Thermal velocity

$$v_{rms} = \sqrt{\frac{3k_B T}{m}}$$

Mass of electron is $9.1 \times 10^{-31} \text{ kg}$, $k_B = 1.38 \times 10^{-23} \text{ J/K}$

$$v_{rms} = \sqrt{\frac{3 \times 1.398 \times 10^{-23} \times 300}{9.1 \times 10^{-31}}} = 1.17 \times 10^5 \text{ m/s}$$

$$\frac{v_d}{v_{rms}} = \frac{0.43}{1.17 \times 10^5} = 0.37 \times 10^{-5}$$

Q) Aluminum wire of diameter 0.25cm is connected in series with a copper wire of diameter 0.16cm. A current of 10Amp is passed through them. Find (a) current density in aluminum wire (b) drift velocity of electrons in copper wire. Given number of free electrons per unit volume of copper wire = 10^{29}

Solution:

a) Radius of aluminum wire = 1.25×10^{-3} m

Cross sectional area of aluminum = $\pi r^2 = (3.14) \times (1.25 \times 10^{-3})^2 = 4.9 \times 10^{-6} \text{m}^2$

Current density in Aluminum $J = I/A$

$$J = \frac{10}{4.9 \times 10^{-6}} = 2.04 \times 10^6 \text{Am}^{-2}$$

b) Radius of copper = 0.8×10^{-3} m

Cross sectional area = $(3.14) \times (0.8 \times 10^{-3})^2 = 2.01 \times 10^{-6} \text{m}^2$

$$v_d = \frac{I}{neA} = \frac{10}{10^{29} \times 1.6 \times 10^{-19} \times 2.01 \times 10^{-6}} = 3.1 \times 10^{-4} \text{m/s}$$

Mobility

In case of conductors free electrons are mobile charge carriers. In case of electrolyte positive and negative ions are mobile charge carriers. In case of semiconductors holes and electrons are mobile charge carriers.

Mobility is defined as drift velocity of charge per unit electric field

$$\mu = \frac{|v_d|}{E}$$

S.I. unit of mobility is m^2/Vs and is 10^4 of mobility in practical units (cm^2/Vs)

By substituting $v_d = \frac{Ee}{m} \tau$ in above equation we get

$$\mu = \frac{e\tau}{m}$$

Limitations of Ohm's Law

- (1) V-I relations are not linear Example: diode transistor
- (2) The relation between V and I depends on the sign of V. If we change the polarity of supply voltage magnitude of current changes
- (3) The relation between V and I is not unique. There may be more values of potential for same current I. example tunnel diode, material Ga,As

Classification of materials based on resistivity :

Materials are classified as conductors, semiconductors and insulators depending on their resistivity.

Conductors have resistivity of order $10^{-8}\Omega\text{m}$ to $10^{-6}\Omega\text{m}$

Insulator have resistivity 10^{18} times greater than metals or more

Resistivity of semiconductors decreases with increase in temperature because covalent bond between adjacent atoms breaks which creates free electrons and holes causing decrease in resistivity. Or its conductivity increases.

Commercially produced resistors for domestic use or in laboratory are of two major types: wire bound resistors and carbon resistors

Wire bound resistors are made by winding the wires of an alloy viz. manganin, constantan, nichrome or similar ones. These alloys are relatively insensitive to temperature. These resistances are typically in the range of a fraction of an ohm or to a few hundred ohms

Resistors, in the higher range are made mostly from carbon. Carbon resistors are compact, inexpensive and thus find extensive use in electronic circuit. Carbon resistors are small in size and hence their values are given using colour code

Temperature dependence of resistivity:

The resistivity of materials is found to be dependent on temperature. Over a limited range of temperatures, that is not too large, the resistivity of metallic conductor is approximately given by

$$\rho_T = \rho_0[1 + \alpha(T - T_0)]$$

Where ρ_T is the resistivity at temperature T and ρ_0 is resistivity at temperature T_0 , α is called the temperature co-efficient of resistivity, dimension of α is $[\text{temperature}]^{-1}$ units are $(^\circ\text{C})^{-1}$ or $(\text{K})^{-1}$

Note that temperature coefficient of Carbon and, semiconductors germanium and silicon are negative, indicating with increase in temperature resistivity decreases.

Equation of resistivity shows a linear relation between temperature and resistivity however graph of resistivity – temperature is not linear for copper.

Since alloys like manganin, constantan, nichrome are relatively insensitive to temperature there graph is straight line intercepting on Y axis

Resistivity of semiconductors decreases with temperature there graph is non linear and have negative slope indicating resistivity decreases with increase in temperature

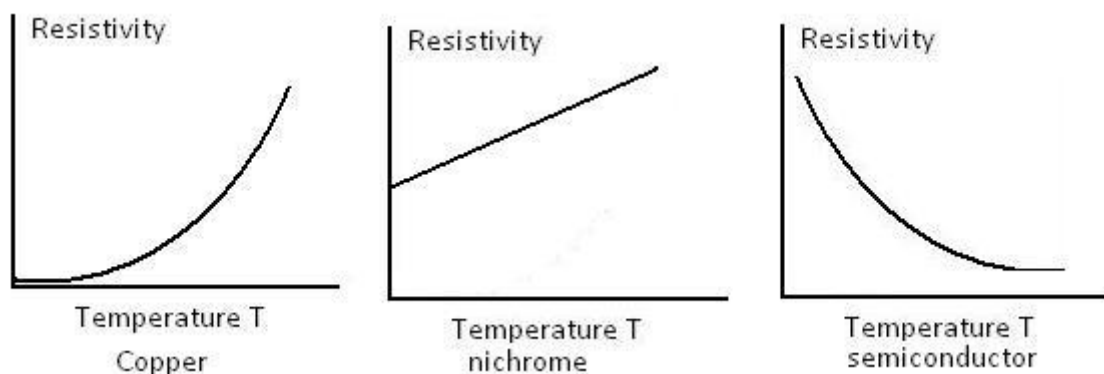

Solved Numerical

Q) A metal wire of diameter 2mm and of length 100m has a resistance of 0.5475 ohm at 20°C and 0.805 ohm at 150°C. Find the values of (i) temperature coefficient of resistance, (ii) its resistance at 0°C (iii) its resistivity at 0°C and 20°C

Solution:

- (i) If R_{20} and R_{150} be the resistance at temperature 20°C and 150°C respectively and α be the temperature coefficient of resistance

$$R_{20} = 0.5475 = R_0 (1 + \alpha \times 20) \text{ -- eq(1)}$$

$$R_{150} = 0.805 = R_0 (1 + \alpha \times 150) \text{ -- eq(2)}$$

Taking ratio of above equations

$$\frac{0.5475}{0.805} = \frac{1 + \alpha \times 20}{1 + \alpha \times 150}$$

$$0.5475(1 + \alpha \times 150) = 0.805(1 + \alpha \times 20)$$

$$0.805 - 0.5475 = 0.5475(\alpha \times 150) - 0.805(\alpha \times 20)$$

$$\alpha = \frac{0.805 - 0.5475}{0.5475 \times 150 - 0.805 \times 20} = 3.9 \times 10^{-3}$$

$$\alpha = 3.9 \times 10^{-3} \text{ } ^\circ\text{C}^{-1}$$

(ii) By substituting value of α in equation (1) we get $R_0 = 0.5079$ ohm

$$(iii) R_0 = \frac{\rho_0 L}{A}$$

$$0.509 = \frac{\rho_0(100)}{\pi(1 \times 10^{-3})^2}$$

$$\rho_0 = 1.596 \times 10^{-8} \text{ ohm m}$$

$$\rho_{20} = \rho_0 (1 + \alpha \times 20)$$

$$\rho_{20} = 1.596 \times 10^{-8} [1 + (3.9 \times 10^{-3} \times 20)]$$

$$\rho_{20} = 1.720 \times 10^{-8} \text{ ohm.m}$$

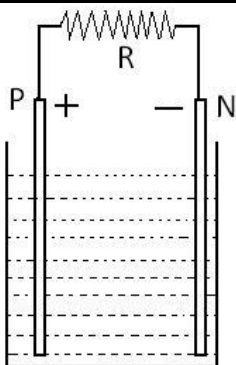
Cells, emf and internal resistance

Cell is a simple device which maintains a steady current in an electrical circuit. Cell consists of electrolyte and electrodes. Electrodes are metallic plate dipped in electrolyte. Due to exchange of electrodes between electrolyte and electrode, one electrode develop positive potential difference (V_+) between electrolyte and electrode and such electrode acts as positive terminal (P). While other electrode develop negative potential difference (V_-) and acts as negative terminal (N). When there is no current, the electrolyte has the same potential throughout,

so that the potential difference between P and N is $V_+ - (-V_-) = V_+ + V_-$.

This difference is called electromotive force (emf) of the cell and is denoted by ϵ . Thus

$$\epsilon = V_+ + V_- > 0$$

emf is work done by non-electrical force in moving a positive charge from negative terminal to positive terminal of battery.

Working of cell:

Consider a wire of resistance R connected across the two terminals of the battery as shown in figure. The electric field is established in wire. As a result positive charge will move from higher potential (P) to lower potential (N) through external resistance R . The energy of the positive charge is consumed to overcome the resistance of wire. As it reaches the negative terminal N , its energy becomes zero, it is as per law of conservation of energy.

Now due to non-electrical force positive charge on the negative electrode is moved towards the positive electrode inside the cell. Thus work is done by the non-electrical force and potential energy of positive charge increases when it reaches positive electrode. Again it flows through the external resistance R and process goes on repeating

Now if external resistance is not connected then positive charge gets accumulated on the positive electrode and produces an electric field in the direction from positive electrode to negative electrode so that direction of electric force is opposite to non-electric force.

When force due to electric field becomes equal to non-electric force flow of positive charge from negative terminal to positive terminal stops and potential across terminal is ϵ . Now during the discharge of cell positive charge has to overcome the resistance of electrolyte, such resistance is called internal resistance denoted by r .

Terminal voltage

When positive charge flows in electrolyte they have to overcome internal resistance r . If I is the current then energy lost in electrolyte is Ir . As a result voltage across P and N is less than ϵ in the open circuit condition. The net energy per unit charge will be $(\epsilon - Ir)$.

Thus, during the flow of current potential across between two terminal P and N is $V = \epsilon - Ir$. This potential difference is called terminal voltage.

If $\epsilon \gg Ir$, internal resistance is neglected

We also observe that since V is the potential difference across resistance R , from Ohm's law $V = IR$

Thus $IR = \epsilon - Ir$

$$I = \frac{\epsilon}{R + r}$$

Maximum current can be drawn from cell is $R = 0$. However, in most of the cells maximum allowed current is much lower to prevent permanent damage to cell.

Internal resistance of electrolyte cell is very small. Thus electrolyte cell gives large value of current. Internal resistance of dry cell is higher thus it gives low current.

Electrical Energy, Power

Consider a conductor with endpoints A and B , in which a current I is flowing from A and B . The electric potential at A and B are denoted $V(A)$ and $V(B)$ respectively.

Since current is flowing from A to B and potential difference across AB is $V = V(A) - V(B) > 0$

In a time interval Δt , an amount of charge $\Delta Q = I \Delta t$ travels from A to B .

The potential energy of charge at $A = \Delta QV(A)$ and

The potential energy of charge at B = $\Delta QV(B)$

Thus change in potential energy

$\Delta U = \text{Final potential energy} - \text{Initial potential energy}$

$\Delta U = \Delta QV(B) - \Delta QV(A) = \Delta Q[V(B) - V(A)]$

$\Delta U = -\Delta QV = -IV \Delta t < 0$

If charges moved without collisions through the conductor, the kinetic energy would also change so that the total energy is unchanged. Conservation of total energy would then imply that.

$\Delta K = -\Delta U$

That is $\Delta K = IV \Delta t > 0$

But when charges flow through the conductor they move with the steady drift velocity, because of collision with ions and atoms during transit. During collisions, energy gained by the charges thus is shared with the atoms. The atoms vibrate more vigorously, as a result conductor heats up. The amount of energy dissipated as heat in the conductor during the time interval is

$$\Delta W = IV \Delta t$$

The energy dissipated per unit time is the power $P = \Delta W / \Delta t$ and we have

$$P = IV$$

Using Ohm's law $V = IR$

$$P = I^2R = V^2/R$$

Power loss is also called as "Ohmic loss"

Power loss in transmission lines

Consider a device of resistance R , to which power is to be delivered via transmission station. Power of device is $P = VI$ or $I = P/V$

Let resistance of transmission cable is R_c . The power dissipated in the connecting wires, which is wasted is $P_c = I^2R_c$

$$P_c = \left(\frac{P}{V}\right)^2 R_c$$

Transmission cables from power stations are hundreds of miles and their resistance R_c is considerable. To reduce P_c voltage V is increased to very large value. Using such high voltage is dangerous, thus at user end voltage is reduced this can be achieved by transformers.

Solved Numerical

Q) What is the resistance of the filament of bulb rated at (100W – 250V)? What is the current through it when connected to 250V line? What will be power if it is connected to a 200V line?

Solution

$$P = \frac{V^2}{R}$$

$$R = \frac{V^2}{P} = \frac{250 \times 250}{100} = 625\Omega$$

The current through the lamp = $P/V = 100/250 = 0.4A$

The power of the lamp when it is connected to a 200V line is

$$P = \frac{V^2}{R} = \frac{200 \times 200}{625} = 64W$$

Q) Forty electric bulb are connected in series across a 220V supply. After one bulb is fused the remaining 39 are connected again in series across same supply. In which case will there be more illumination and why?

Solution

Let r be the resistance of each bulb and 40 bulb in series have a resistance of $40r\Omega$. When connected across a supply voltage V , the power of the system with 40 bulb will be

$$P_{40} = \frac{V^2}{40r}$$

When one bulb is fused, the resistance of the remaining 39 bulb in series $=39r$ and the power of the system when connected to the same supply

$$P_{39} = \frac{V^2}{39r}$$

It is clear that $\frac{V^2}{39r} > \frac{V^2}{40r}$

Therefore power of 39 bulb in series is greater.

Series Combination of resistors

Two resistors are said to be connected in series, if only one end of their ends points are joined. In series connection current flowing through each resistor remains same, while sum of potential drop across resistors is equal to potential drop across combination

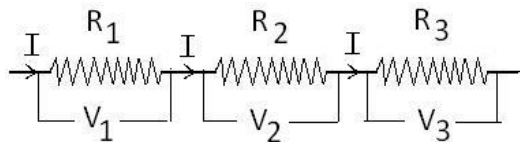

Consider three resistor R_1, R_2 and R_3 are connected in series as shown in figure.

Potential difference across R_1 is $V_1 = IR_1$

Potential difference across R_2 is $V_2 = IR_2$

Potential difference across R_3 is $V_3 = IR_3$

The potential difference across combination is $V = V_1 + V_2 + V_3$

$$V = I (R_1 + R_2 + R_3)$$

If R_{eq} is equivalent resistance and V is potential difference across combination then

$$V = I (R_{eq})$$

$$\text{Thus } R_{eq} = R_1 + R_2 + R_3$$

IF n resistance are connected in series the $R_{eq} = R_1 + R_2 + R_3 + \dots + R_n$

Parallel combination of resistors

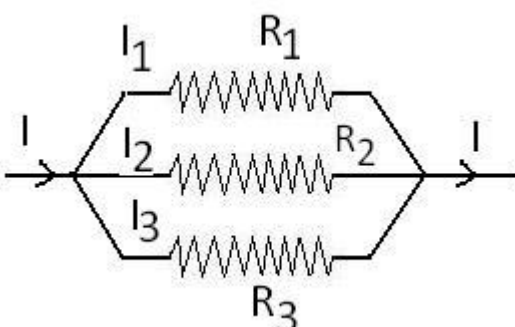

Two or more resistors are said to be connected in parallel if one end of all the resistors is joined together and similarly the other ends are joined together as shown in figure.

In parallel combination current gets divided depending up on value of resistor, sum of current passing through the resistor is equal to current

passing through combination, but potential difference across each resistor is equal to potential difference across combination

Here I_1 , I_2 and I_3 are the currents passing through the resistors as shown in figure

If I is the current passing through the combination then $I = I_1 + I_2 + I_3$

By applying Ohms law we get voltage across R_1 as $V = I_1 R_1$ or $I_1 = V/R_1$

Similarly $I_2 = V/R_2$ and $I_3 = V/R_3$

By substituting values of current in above equation we get

$$I = \frac{V}{R_1} + \frac{V}{R_2} + \frac{V}{R_3}$$

$$I = V \left(\frac{1}{R_1} + \frac{1}{R_2} + \frac{1}{R_3} \right)$$

If combination is replaced by equivalent resistance R_{eq} , we would have from Ohm's law

$$I = V/R_{eq}$$

From above equations we have

$$\frac{1}{R_{eq}} = \frac{1}{R_1} + \frac{1}{R_2} + \frac{1}{R_3}$$

If n resistors are connected in parallel the equivalent resistance

$$\frac{1}{R_{eq}} = \frac{1}{R_1} + \frac{1}{R_2} + \frac{1}{R_3} + \dots + \frac{1}{R_n}$$

Cells in series

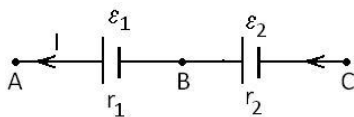

Consider first two cells in series, where one terminal of the two cells is joined together leaving the other terminal in either cell free. Let ϵ_1 and ϵ_2 be the emf of the two cell having internal resistance r_1 and r_2 respectively

Let $V(A)$, $V(B)$, $V(C)$ be the potentials at points A, B and C shown in figure.

Then $V(A) - V(B)$ is the potential difference between the positive and negative terminals of the first cell.

We know that terminal voltage of first cell $V_{AB} = V(A) - V(B) = \epsilon_1 - I r_1$

Similarly for second cell $V_{BC} = V(B) - V(C) = \epsilon_2 - I r_2$

Hence, the potential difference between the terminals A and C of the combination is

$$V_{AC} = V(A) - V(C) = V(A) - V(B) + [V(B) - V(C)] = \epsilon_1 - I r_1 + (\epsilon_2 - I r_2)$$

$$V_{AC} = (\epsilon_1 + \epsilon_2) - I(r_1 + r_2)$$

If we wish to replace the combination by a single cell between A and C of emf ϵ_{eq} and internal resistance r_{eq} , we would have

$$V_{AC} = \epsilon_{eq} - I r_{eq}$$

Comparing the last two equations, we get $\epsilon_{eq} = \epsilon_1 + \epsilon_2$ and $r_{eq} = r_1 + r_2$

If polarity of second cell is reverse then $\epsilon_{eq} = \epsilon_1 - \epsilon_2$ ($\epsilon_1 > \epsilon_2$)

Note:

(i) The equivalent emf of a series combination of n cells is just the sum of their individual emf's, and

(ii) The equivalent internal resistance of a series combination of n cells is just the sum of their internal resistances

If n cells of emf ϵ having internal resistance r each connected in series. Total current I if resistance R connected across combination

$$I = \frac{n\epsilon}{R + nr}$$

Cells in parallel

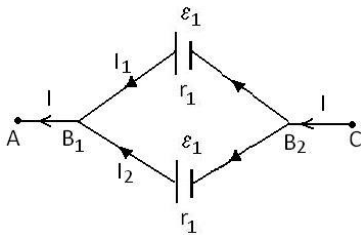

Consider a parallel combination of the cells as shown in figure. I_1 and I_2 are the currents leaving the positive electrodes of the cells. At the point B_1 , I_1 and I_2 flow out whereas the current I flows in B_2 . Since as much charge flows in as out, we have $I = I_1 + I_2$

Let $V(B_1)$ and $V(B_2)$ be the potentials at B_1 and B_2 , respectively. Then, considering the first cell, the potential

difference across its terminals is $V(B_1) - V(B_2)$. Hence

$$V = V(B_1) - V(B_2) = \epsilon_1 - I r_1$$

$$I_1 = \frac{\epsilon_1 - V}{r_1}$$

Points B_1 and B_2 are connected exactly similarly to the first cell. Hence considering the second cell, we also have

$$V = V(B_1) - V(B_2) = \epsilon_2 - I r_2$$

$$I_2 = \frac{\epsilon_2 - V}{r_2}$$

Combining the last three equations we get

$$I = \frac{\epsilon_1 - V}{r_1} + \frac{\epsilon_2 - V}{r_2} = \left(\frac{\epsilon_1}{r_1} + \frac{\epsilon_2}{r_2} \right) - V \left(\frac{1}{r_1} + \frac{1}{r_2} \right)$$

If we want to replace the combination by a single cell, between B_1 and B_2 , of emf ϵ_{eq} and internal resistance r_{eq} , we would have

$$V = \epsilon_{eq} - I r_{eq}. \text{ Thus}$$

$$\epsilon_{eq} = \frac{\epsilon_1 r_2 + \epsilon_2 r_1}{r_1 + r_2}$$

$$r_{eq} = \frac{r_1 r_2}{r_1 + r_2}$$

In simpler way

$$\frac{1}{r_{eq}} = \frac{1}{r_1} + \frac{1}{r_2}$$

$$\frac{\epsilon_{eq}}{r_{eq}} = \frac{\epsilon_1}{r_1} + \frac{\epsilon_2}{r_2}$$

General formula for n cells

$$\frac{1}{r_{eq}} = \frac{1}{r_1} + \frac{1}{r_2} + \dots + \frac{1}{r_n}$$

$$\frac{\varepsilon_{eq}}{r_{eq}} = \frac{\varepsilon_1}{r_1} + \frac{\varepsilon_2}{r_2} + \dots + \frac{\varepsilon_n}{r_n}$$

If n cells of emf ε having internal resistance r each connected in parallel. Total current I if resistance R connected across combination

$$I = \frac{\varepsilon}{R + \frac{r}{m}} = \frac{m\varepsilon}{mR + r}$$

Mix grouping of cell

Let n identical cells be arranged in series and let m such rows be connected in parallel.

Total numbers of cells are nm

Emf of system = $n\varepsilon$

Internal resistance of the system = nr/m

The current through the external resistance R

$$I = \frac{n\varepsilon}{R + \frac{nr}{m}} = \frac{mn\varepsilon}{mR + nr}$$

Solved Numerical

Q) Six cells are connected (a) in series (b) in parallel (c) in 2 rows each containing 3 cells. The emf of each cell is 1.08 V and its internal resistance is 1 ohm . Calculate the current that would flow through an external resistance of 5ohm in the three cases

Solution

(a) The cells are in series

Total emf = $n\varepsilon = 6 \times 1.08 = 6.48$

Total internal resistance = $nr = 6 \times 1 = 6$ ohm

The current in circuit = Total potential / total resistance

$$I = \frac{n\varepsilon}{R + nr} = \frac{6.48}{5 + 6} = 0.589A$$

(b) The cells are in parallel

Here $\varepsilon = 1.08V$,

internal resistances are in parallel total internal resistance is $r' = r/m = r/6 = 1/6$ ohm

The current in circuit = Total potential / total resistance

$$I = \frac{\varepsilon}{R + r/m} = \frac{1.08}{5 + \frac{1}{6}} = 0.209A$$

(c) The cells in multiple arc with n = 3 and m = 2

$$I = \frac{mn\varepsilon}{mR + nr} = \frac{6 \times 1.08}{(2 \times 5) + (3 \times 1)}$$

$$I = \frac{6.48}{13} = 0.498A$$

Arrangements of cells for maximum current

$$I = \frac{n\varepsilon}{R + \frac{nr}{m}} = \frac{mn\varepsilon}{mR + nr}$$

Current will be maximum if $(mr+nr)$ should be minimum.

This happens if $mR = nr$

Or $R = nr/m$

Hence the current through the external resistance R is a maximum when it is equal to internal resistance of the battery (nr/m)

Kirchhoff's rules

Electric circuits generally consist of a number of resistors and cells interconnected sometimes in a complicated way.

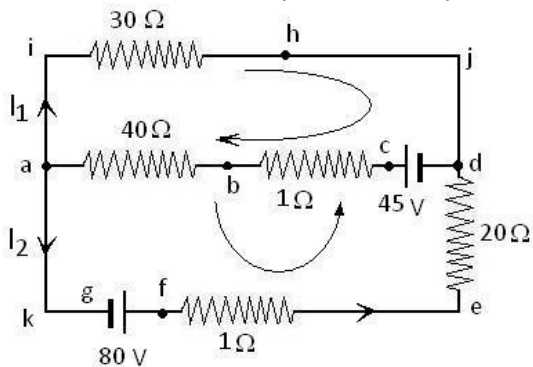

Junction or Branch point: The point in network at which more than two conductors meet is called a junction or a branch point . Point a and d shown in figure are junction point .

Loop: A closed circuit formed by conductors is known as loop. As shown in figure ihjdcba forms a closed loop

Kirchhoff's first rule or junction rule:

At any junction, the sum of the currents entering the junction is equal to the sum of currents leaving the junction.

The proof of this rule follows from the fact that when currents are steady, there is no accumulation of charges at any junction or at any point in a line. Thus, the total current flowing in, (which is the rate at which charge flows into the junction), must equal the total current flowing out.

Proof : Let $Q_1, Q_2 \dots Q_5$ be electrical charges flowing through the cross-sectional area of the respective conductors in time interval t which constitute current $I_1, I_2, \dots I_5$

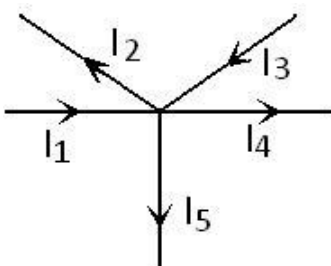

Hence $Q_1 = I_1t, Q_2 = I_2t, \dots Q_5 = I_5t$

It is evident from figure that the total electric charge entering the junction is $Q_1 + Q_3$, while $Q_2 + Q_4 + Q_5$ amount of charge is leaving the junction in the same interval of time

Thus $Q_1 + Q_3 = Q_2 + Q_4 + Q_5$

$$\therefore I_1t + I_3t = I_2t + I_4t + I_5t$$

$$I_1 + I_3 - I_2 - I_4 - I_5 = 0$$

$$\therefore \sum I = 0.$$

Kirchhoff's second rule or Loop rule: *The algebraic sum of changes in potential around any closed loop involving resistors and cells in the loop is zero*

Using law of conservation of energy and the concept of electric potential any closed circuit can be analyzed. In electric circuit, the electric potential at any point is a steady circuit does not change with time.

Following are the sign convention has to be followed:

- (i) If our selected path is in the direction of current then potential drop across resistor should be taken as negative else it should be taken as positive

- (ii) The emf of a battery should be considered negative while moving from negative terminal of a battery to the positive terminal. The emf of battery is taken as positive while moving from positive terminal while moving from positive to negative terminal of battery

While analyzing the circuit we may get negative value of current indicates direction of current which arbitrarily chosen is opposite to the actual direction of current

Solved Numerical

- Q) A potential divider of resistance 500 ohm is used to obtain variable voltages from a supply main of 200V. Determine the position of the tapping point C to get a current of 2A through a resistance of 30 ohm connected across A and C as shown

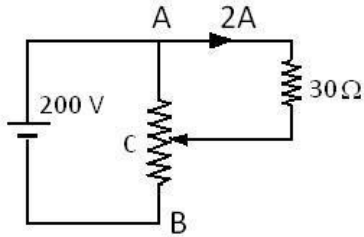

Solution:

Let the resistance of the potential divider between A and C be R ohm

The potential difference across the 30ohm resistor = $2 \times 30 = 60V$

\therefore The voltage drop across AC of the potential divider = 60V

Current flowing through R $I = 60/R$

Now the voltage drop across BC = $200 - 60 = 140V$

The current through BC is $I' = 140 / (500 - R)$

Now

$$\frac{140}{500 - R} = \frac{60}{R} + 2$$

Solving $R = 434.7$ ohm

Hence the tapping point C lies in such position that the length AC is $\frac{434.7}{500} = 0.8694$ of the length AB

- Q) Find the current in the resistors of the circuit given. The internal resistance of the battery are included in the external resistances.

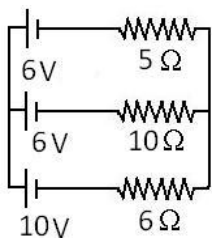

Solution:

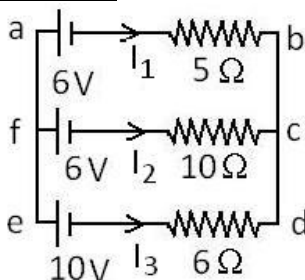

From adjacent figure

Taking loop abcfa applying kirchhoff's second law

$$-6 - 5I_1 + 10I_2 + 6 = 0$$

$$-5I_1 + 10I_2 = 0$$

$$I_1 = 2I_2 \text{---eq(1)}$$

Taking loop fcbed

$$-6 - 10I_2 + 6I_3 + 10 = 0$$

$$-10I_2 + 6I_3 + 4 = 0$$

$$-5I_2 + 3I_3 + 2 = 0 \quad \text{--eq(2)}$$

Applying the junction rule to junction a $I_1 + I_2 + I_3 = 0$ --eq(3)

On simplifying eq(1), (2) and (3) we get

$$I_1 = (2/7)A, I_2 = (1/7)A, I_3 = (-3/7)A$$

The direction of flow of I_3 is opposite to that marked in the circuit

Wheatstone bridge

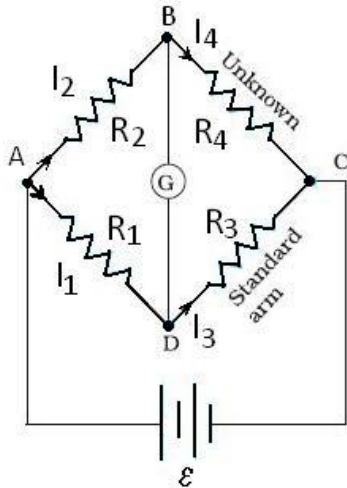

The circuit shown in figure which is called the Wheatstone bridge. The bridge has four resistors R_1 , R_2 , R_3 and R_4 .

Across one pair of diagonally opposite points (A and C in the figure) a source is connected. This (i.e., AC) is called the battery arm.

Between the other two vertices, B and D, a galvanometer G (which is a device to detect currents) is connected. This line, shown as BD in the figure, is called the galvanometer arm.

For simplicity, we assume that the cell has no internal resistance. In general there will be currents flowing across all the resistors as well as a current I_g through G. Of special interest, is the case of a balanced bridge where the resistors

are such that $I_g = 0$.

We can easily get the balance condition, such that there is no current through G. In this case, the Kirchhoff's junction rule applied to junctions D and B (see the figure)

immediately gives us the relations $I_1 = I_3$ and $I_2 = I_4$. Next, we apply Kirchhoff's loop rule to closed loops ADBA and CBDC.

The first loop gives ADBA

$$-I_1R_1 + 0 + I_2R_2 = 0 \quad (I_g = 0)$$

$$\frac{I_1}{I_2} = \frac{R_2}{R_1}$$

and the second loop CBDC. And using $I_1 = I_3$ and $I_2 = I_4$

$$I_2R_4 + 0 - I_1R_3 = 0$$

$$\frac{I_1}{I_2} = \frac{R_4}{R_3}$$

Hence at balanced condition from above equation

$$\frac{R_2}{R_1} = \frac{R_4}{R_3}$$

This last equation relating the four resistors is called the balance condition for the galvanometer to give zero or null deflection.

The Wheatstone bridge and its balance condition provide a practical method for determination of an unknown resistance. Let us suppose we have an unknown resistance, which we insert in the fourth arm; R_4 is thus not known. Keeping known resistances R_1

and R_2 in the first and second arm of the bridge, we go on varying R_3 till the galvanometer shows a null deflection. The bridge then is balanced, and from the balance condition the value of the unknown resistance R_4 is given by,

$$R_4 = R_3 \frac{R_2}{R_1}$$

Meter bridge

The meter bridge is shown in Figure

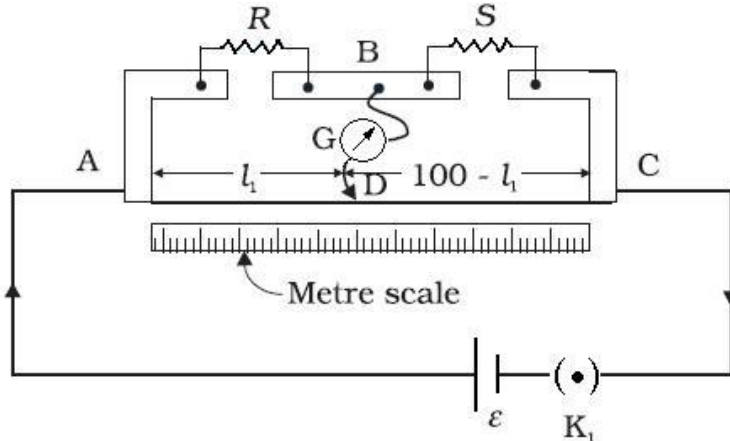

It consists of a wire of length 1m and of uniform cross sectional area stretched taut and clamped between two thick metallic strips bent at right angles, as shown.

The metallic strip has two gaps across which resistors can be connected. The end points where the wire is clamped are connected to a cell through a key.

One end of a galvanometer is connected to the metallic strip midway between the two gaps. The other end of the galvanometer is connected to a 'jockey'. The jockey is essentially a metallic rod whose one end has a knife-edge which can slide over the wire to make electrical connection.

R is an unknown resistance whose value we want to determine. It is connected across one of the gaps. Across the other gap, we connect a standard known resistance S . The jockey is connected to some point D on the wire, If the jockey is moved along the wire, then there will be one position where the galvanometer will show no current.

Let the distance of the jockey from the end A at the balance point be $l = l_1$.

The four resistances of the bridge at the balance point then are R , S , ρl_1 and $\rho (100 - l_1)$.

The balance condition,

$$\frac{R}{S} = \frac{\rho l_1}{\rho(100 - l_1)} = \frac{l_1}{100 - l_1}$$

Thus, once we have found out l_1 , the unknown resistance R is known in terms of the standard known resistance S by

$$R = S \frac{l_1}{100 - l_1}$$

By choosing various values of S , we would get various values of l_1 , and calculate R each time. An error in measurement of l_1 would naturally result in an error in R . It can be shown

that the percentage error in R can be minimized by adjusting the balance point near the middle of the bridge, i.e., when l_1 is close to 50 cm.

Potentiometer

Construction

It is basically a long piece of uniform wire, sometimes a few meters in length across which a standard cell is connected. In actual design, the wire is sometimes cut in several pieces placed side by side and connected at the ends by thick metal strip.

In the figure, the wires run from A to C. The small vertical portions are the thick metal strips connecting the various sections of the wire. A current I flows through the wire which can be varied by a variable resistance (rheostat, R) in the circuit.

Use to compare emf

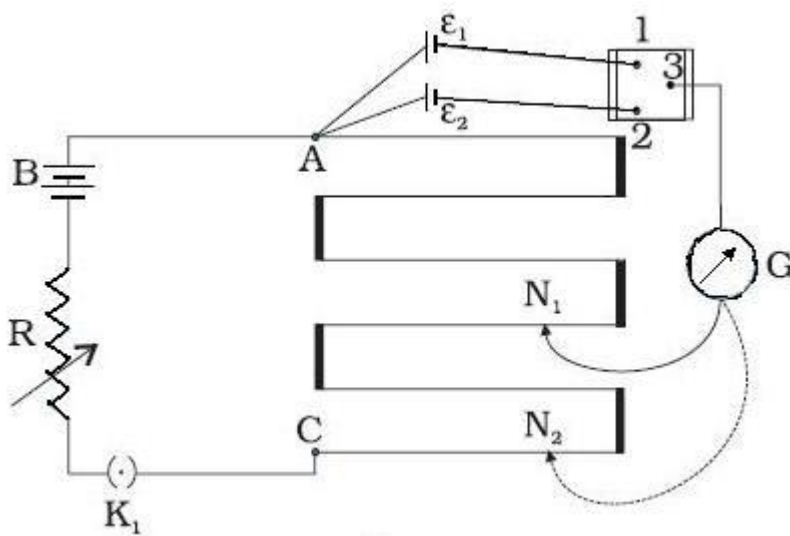

Since the wire is uniform, the potential difference between A and any point at a distance l from A is $\epsilon(l) = \phi l$ (where ϕ is the potential drop per unit length).

Figure shows an application of the potentiometer to compare the emf of two cells of emf ϵ_1 and ϵ_2 . The points marked 1, 2, 3 form a two way key.

Consider first a position of the key where 1 and 3 are connected so that the galvanometer is connected to ϵ_1 . The jockey is moved along the wire till at a point N_1 , at a distance l_1 from A, there is no deflection in the galvanometer. We can apply Kirchhoff's loop rule to the closed loop AN_1G31A and get,

$\phi l_1 + 0 - \epsilon_1 = 0$ Similarly, if another emf ϵ_2 is balanced against l_2 (AN_2)

$\phi l_2 + 0 - \epsilon_2 = 0$ From the last two equations

$$\frac{\epsilon_1}{\epsilon_2} = \frac{l_1}{l_2}$$

Thus we can compare the emf's of any two sources. In practice one of the cells is chosen as a standard cell whose emf is known to a high degree of accuracy. The emf of the other cell is then easily calculated from above equation

use to measure internal resistance of a cell

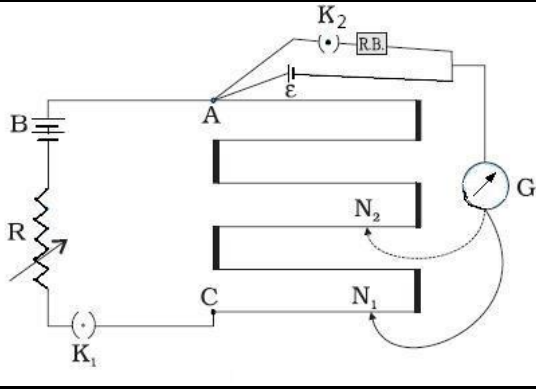

For this the cell (emf ϵ) whose internal resistance (r) is to be determined is connected across a resistance box through a key K_2 , as shown in the figure. With key K_2 open, balance is obtained at length l_1 (AN_1). Then,

$$\epsilon = \phi l_1$$

When key K_2 is closed, the cell sends a current (I) through the resistance box (R). If V is the terminal potential difference of the cell and balance is obtained at length l_2 (AN_2),

$$V = \phi l_2$$

So, we have

$$\frac{\epsilon}{V} = \frac{l_1}{l_2}$$

But, $\epsilon = I(r + R)$ and $V = IR$. This gives

$$\frac{\epsilon}{V} = \frac{(r + R)}{R}$$

From above equations we have

$$\frac{(r + R)}{R} = \frac{l_1}{l_2}$$

$$r = R \left(\frac{l_1}{l_2} - 1 \right)$$

Using above we can find the internal resistance of a given cell.

The potentiometer has the advantage that it draws no current from the voltage source being measured. As such it is unaffected by the internal.

-----END-----

To become a member of www.gneet.com give call on 09737240300